

# TERRACLEAR

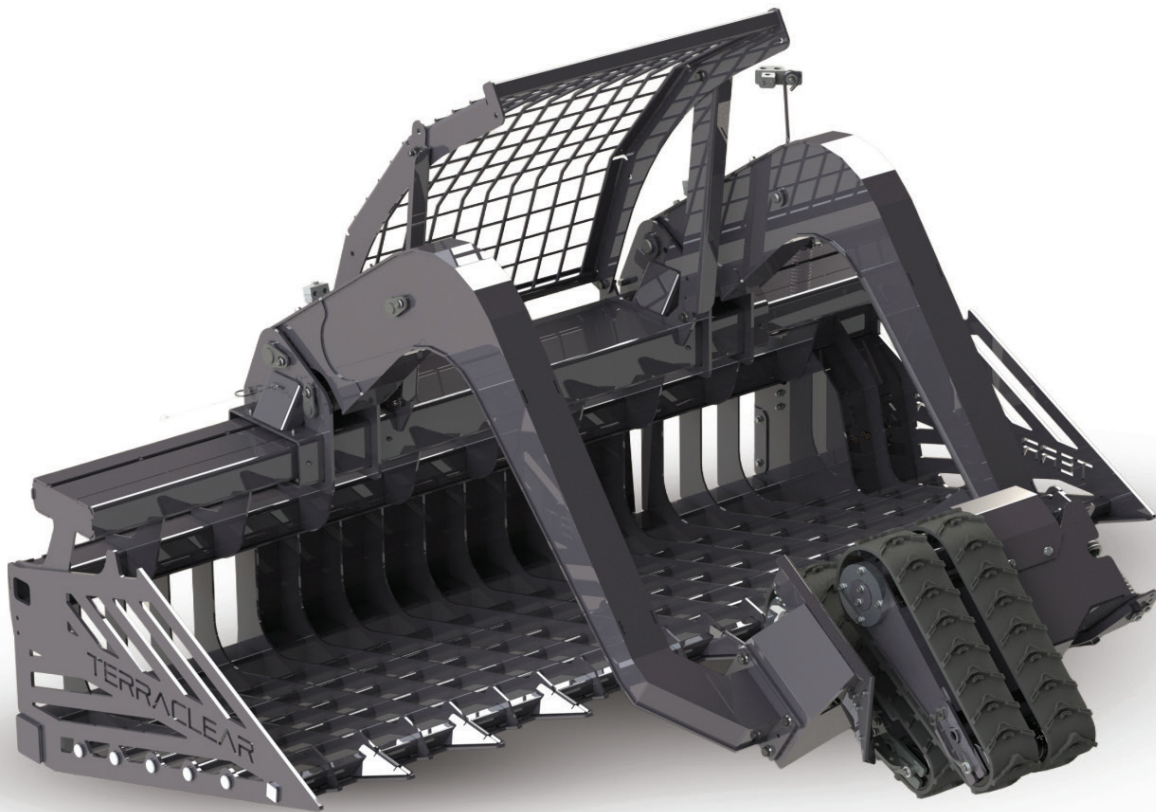

Scan QR code for  
the digital manual



## Rock Picker TC100

Operator's Manual  
with Replacement Parts Section

# Limited Warranty

**A. GENERAL PROVISIONS** – The warranty described below is provided by TerraClear, Inc. (“TerraClear”) to the original Customer. This warranty does not apply to the vehicle (“Carrier Vehicle”) the Product is attached to. TerraClear will repair or replace, at its option, any covered part which is found to be defective in material or workmanship during the applicable warranty term. Only new or remanufactured parts or components approved by TerraClear will be used. The Customer will be responsible, however, for any service call and/or transportation of the Product to and from the service center’s place of business, for any labor required for repair or replacement of parts, including any premium charged for overtime labor requested by the Customer, and for any service and/or maintenance not directly related to any defect covered under the warranties below. Service must be performed only by a certified service center or dealer approved by Company. This warranty is NOT transferable.

**B. WHAT IS WARRANTED** – 1-year (12 month) parts warranty from the Product Delivery Date.

**C. WHAT IS NOT WARRANTED – TERRACLEAR IS NOT RESPONSIBLE FOR THE FOLLOWING:** (1) Any Product no longer owned by the original Customer; (2) Any Product that has been altered or modified in ways not approved by TerraClear; (3) Depreciation or damage caused by normal wear, including wear items such as belts, idlers, paint, hydraulic hoses and fittings, are excluded from the Warranty; (4) Depreciation or damage caused by lack of reasonable and proper maintenance, failure to follow operating instructions and warnings, misuse, lack of proper protection during storage, or accident; (5) Normal maintenance parts and services; (6) Any Product being rented or loaned to a third party by Customer.

**D. SECURING WARRANTY SERVICE** –To secure warranty service, the Customer must (1) Report the Product issue to TerraClear, Inc. by calling 1-712-513-2809, option 2 within the applicable warranty term, (2) Present evidence of the Product Delivery Date.

**E. LIMITATION OF WARRANTIES AND OTHER REMEDIES** – THIS WARRANTY IS IN LIEU OF ALL WARRANTIES OF MERCHANTABILITY, FITNESS FOR PARTICULAR PURPOSE OR ANY OTHER WARRANTIES, EXPRESS OR IMPLIED. CORRECTION OF NONCONFORMITIES IN THE MANNER AND FOR THE PERIOD OF TIME PROVIDED ABOVE, SHALL CONSTITUTE FULFILLMENT OF ALL LIABILITIES OF SELLER TO BUYER, WHETHER BASED ON CONTRACT, NEGLIGENCE OR OTHERWISE WITH RESPECT TO OR ARISING OUT OF SUCH GOODS.

NO WARRANTY IS OFFERED BY COMPANY (1) TO CUSTOMERS BASED OUTSIDE OF THE UNITED STATES OR CANADA, OR (2) FOR ANY SALES MADE OUTSIDE OF THE UNITED STATES OR CANADA. PRODUCTS USED, OR INTENDED TO BE USED, OUTSIDE OF THE UNITED STATES OR CANADA ARE SOLD “AS-IS”, AND WITHOUT A WARRANTY FROM COMPANY.

NEITHER PARTY SHALL BE LIABLE FOR SPECIAL, INDIRECT, INCIDENTAL, PUNITIVE, OR CONSEQUENTIAL DAMAGES. THE REMEDY SET FORTH IN THIS INSTRUMENT IS EXCLUSIVE, AND THE LIABILITY OF SELLER WITH RESPECT TO ANY CONTRACT OR SALE OF ANYTHING DONE IN CONNECTION WITH THE SAME, WHETHER IN CONTRACT, IN TORT, UNDER WARRANTY, OR OTHERWISE, SHALL NOT EXCEED THE PRICE OF THE GOODS OR PART UPON WHICH SUCH LIABILITY IS ALLEGEDLY BASED.

\* Note: Some states do not allow exclusions of incidental or consequential damages, or limitations on how long an implied warranty lasts, so the above exclusions may not apply to you.

# TERRACLEAR



Warranty

Table of Contents

Introduction

Owner Information . . . . . 1
Intended Use . . . . . 1
Using this Manual. . . . . 1
Owner Assistance. . . . . 1
Warranty Policy. . . . . 1
Serial Number Location . . . . . 1
Operator's Manual Access . . . . . 1

Safety Instructions

Safety Information. . . . . 3
Safety Signal Words . . . . . 3
Owner's Responsibility . . . . . 3
Emergency Preparedness. . . . . 4
Mandatory Shut-Down Procedure . . . . . 4
General Safety Requirements . . . . . 4
Safety Precautions for Bystanders. . . . . 4
Transport Safety . . . . . 4
Utilities Safety. . . . . 4
Raised Attachment. . . . . 5
Hydraulic Safety . . . . . 5
California Proposition 65 Warning . . . . . 5
Safety Labels . . . . . 5
Decals . . . . . 8
Serial Number Tag . . . . . 8
TC100 Rock Picker Component Identification . . . . . 9
TC100 Rock Picker Functions . . . . . 10

Set-up Instructions

Setting Up Auxiliary Control Connector . . . . . 11
Installing the Harness Wiring into the Plug. . . . . 11
Connecting the Harness to the Rock Picker . . . . . 12
Attaching and Detaching the Rock Picker . . . . . 12
Attaching . . . . . 12
Hydraulic and Harness Connections . . . . . 13
Detaching. . . . . 13
Startup . . . . . 13
Starting. . . . . 13
Testing. . . . . 14
Shutdown . . . . . 14

**Operating Instructions**

Controls and Functions . . . . . 15  
 Break-in Time . . . . . 15  
 Operation Safety . . . . . 15  
 Operating Instructions . . . . . 15  
     Guidelines . . . . . 15  
     Rock Picking . . . . . 15  
     Dumping . . . . . 16  
 Transporting . . . . . 16  
     Road Travel . . . . . 16  
     Hauling . . . . . 16  
 Troubleshooting . . . . . 17

**Maintenance**

General Maintenance . . . . . 19  
     Maintenance Safety . . . . . 19  
 Maintenance Schedule . . . . . 19  
 Lubrication . . . . . 19  
     Grease Point Locations . . . . . 19  
 Belt Tensioning and Replacement . . . . . 20  
     Releasing Spring Tension . . . . . 21  
     Lower Paddle Belt Tensioning/Replacement . . . . . 21  
     Upper Paddle Belt Tensioning/Replacement . . . . . 25  
     Setting Spring Tension . . . . . 25  
     Recoupling Right Arm to the Paddle Assembly . . . . . 26  
 Rock Guard Adjustment . . . . . 27  
 Storage . . . . . 28  
     End of Season . . . . . 28  
     Beginning of the Season . . . . . 28

**Parts Identification**

Bucket, Valve Cover, Misc. . . . . 30  
 Sideshift Cylinder, with Hydraulic Support . . . . . 31  
 Rock Picker Arms . . . . . 32  
 Paddle Assembly . . . . . 33  
 Upper Paddle Assembly . . . . . 34  
 Lower Paddle . . . . . 36  
 Carriage Assembly . . . . . 38  
 Hydraulic Valve . . . . . 39  
 Hydraulic Hoses, with Schematic . . . . . 40

**Appendix**

Electrical Schematic . . . . . 41  
 Specifications . . . . . 42  
 Dimensions . . . . . 43  
 Torque Specifications . . . . . 44  
     Inches Hardware and Lock Nuts . . . . . 44  
     Metric Hardware and Lock Nuts . . . . . 45

**Owner Information**

Thank you for purchasing your new TC100 Rock Picker from TerraClear. We welcome you to our growing family of new product owners. Proper assembly, maintenance, and safe operating practices will help you get years of satisfactory use from this rock picker.

**Intended Use**

The TC100 Rock Picker is a farming implement designed and built by TerraClear, Inc. and is intended to be installed on a compatible compact track loader for use in picking rocks in farm fields. It is not designed to be used for any other purpose other than its intended use.

**Using this Manual**

This manual is designed to help familiarize the operator with the safety, assembly, operation, adjustments, troubleshooting, and maintenance expectations of this implement and create awareness of the hazards that may be encountered due to its use. The intent of this manual is to provide specific user instructions and guidelines to help owners and operators obtain the best results from their implement with a focus on safe operation and accident and injury prevention.

All users must read and understand the information in this manual prior to operation. Failure to follow the procedures described in this manual could result in implement damage or physical injury or death to the operator or bystanders.

Keep this manual with the implement for future reference, as it is considered part of your implement. Please refer to the manual for preventative maintenance procedures to maximize the productivity and lifespan of your implement.

The information contained within this manual is current at the time of printing. TerraClear reserves the right to make changes in materials or design of the product and its manual at any time without notice.

**Owner Assistance**

Do not modify the implement or use with attachments other than TerraClear-provided options and accessories specified for use with this product.

Contact TerraClear if service or repair parts are needed. TerraClear has trained personnel, repair parts, and equipment needed to service this implement.

At any point in time, if for any reason you do not understand the instructions or safety requirements in this manual, or require clarification on safe operating procedures, please contact our service and support team. +1 (425)-274-2905.

**Warranty Policy**

Be sure to read and understand the Limited Warranty at the beginning of this manual. It is also important that you fill out the warranty registration form(s) completely.

**Serial Number Location**



The serial number tag for your machine is located on the rear of the rock picker. It is also stamped into the frame, to the right of the mount.

Always use your model and serial number when requesting information or when ordering parts.

**Operator's Manual Access**

An operator's manual for the TC100 Rock Picker is available for download on the TerraClear website at the following link:

<https://www.terraclear.com/products-rock-picker/TC100-manual>.

Additionally, a QR code is located next to the stamped serial number on the rear of the machine. Scan the code with a smartphone to access the digital manual on the TerraClear website.

## Safety Information

### Safety Signal Words

The safety labels on the implement and safety messages in this manual use a combination of symbols, signal words, and color-coding to identify the following hazardous situations or safety practices:



**DANGER** indicates a hazardous situation which, if not avoided, will result in death or serious injury.



**WARNING** indicates a hazardous situation which, if not avoided, could result in death or serious injury.



**CAUTION** indicates a hazardous situation which, if not avoided, could result in minor or moderate injury.

**IMPORTANT:** **IMPORTANT** indicates a point of information related to the following topic. This information must be read and understood before continuing.

**NOTE:** **NOTE** indicates a special point of information that the operator should be aware of before continuing. It is also used to address practices not related to physical injury.

**Be certain all machine operators are aware of the dangers indicated by safety decals applied to the machine, and be certain they follow all safety decal instructions. Contact TerraClear for safety decal replacement.**

**TerraClear cannot anticipate every possible circumstance that may involve a potential hazard. The warnings in this operator's manual are not all inclusive.**

## Owner's Responsibility

When operating this implement, you are responsible for your own safety and the safety of those around you.

It is mandatory that all personnel read and follow all safety precautions before operating the machine and attachment.

Make sure that all personnel have read this operator's manual, and thoroughly understand safe and correct installation, operation, and maintenance procedures.

This implement is designed and equipped with proper safety features, including implement guards and safety labels, to protect you and bystanders from hazards that could cause serious injury. Guards and safety labels serve a critical purpose and must not be altered. Guards should only be removed for maintenance purposes and must be reinstalled prior to operation.

**NOTE:** *Some of the illustrations in this manual may show the implement with implement guards removed for clarity. Never operate the implement unless all implement guards are in place.*

Due to the potential danger of flying debris, it is the owner's responsibility and is mandatory that impact-resistant shielding be installed on the loader to protect the operator.

**IMPORTANT:** *Ensure that the track loader's windshield is equipped with impact-resistant glass or that an appropriate protective guard is in place when operating the rock picker. TerraClear is not responsible for any damage to the windshield, or any other part of the track loader, caused by flying rocks or debris.*

Operate and maintain this machine in a safe manner and in accordance with all applicable local, state, and federal codes, regulations and/or laws; and in compliance with on-product labeling and this operator's manual instructions.

Make sure that all personnel know how to stop the machine and attachment by disengaging all controls. See "Mandatory Shut-Down Procedure" on page 4.

Make sure the rock picker is installed correctly before being placed in service. At regular intervals thereafter, the attachment should be serviced in accordance with procedures outlined in this operator's manual.

# TERRACLEAR

## Emergency Preparedness

Ensure that you are prepared for emergencies when operating the implement.

- Keep a fire extinguisher and first aid kit close to the implement.
- Make note of emergency phone numbers.
- Know your location and ensure others can locate you if an emergency were to occur.

## Mandatory Shut-Down Procedure

- Stop the power unit with attachment on a level surface, and disengage all power to the attachment. Lower the attachment to the ground.
- Move throttle to idle position.
- Shut off engine and remove the key.

Wait until the implement has stopped completely before inspecting the attachment.

## General Safety Requirements

**These general safety requirements apply to the overall use and maintenance of this implement. In addition to this safety section, you must also refer to the safety messages and instructions in each of the appropriate sections of this manual. Each section provides further details on section, or task-specific safety messages that alert you about hazards associated with normal use and foreseeable misuse of the implement.**

## Safety Precautions for Bystanders

### WARNING

The operator must ensure bystanders are following proper safety practices around the implement.

- All bystanders must stand at least 15 feet from the implement when in use.
- Do not lift or carry anyone on the implement.
- Do not use the implement as a work platform.
- Do not allow untrained personnel or children to operate this implement.

## Transport Safety

### WARNING

Follow safe transport practices during transport.

- Transport only on a flat, level surface that is approved under state and local legal regulations.
- Ensure the bottom of the bucket is fully in contact with the surface on which the implement will be transported.
- Ensure the arm is lowered and in contact with the surface on which the implement will be transported.
- Do not allow any part of the implement to extend past the surface on which the implement will be transported.
- Secure every point of contact with the surface on which the implement will be transported, using safety chains, within state and local legal regulations.
- Make sure that the bucket is empty and clear of rocks that may come loose during transport.

## Utilities Safety

### WARNING

Take measures to ensure no damage is caused by digging into the ground with the implement or raising the implement into the air.

- Only use the rock picker to pick rock.
- Only use the rock picker to dig into the ground if in a farm field, only to reach a rock, no more than 6 in. (15.25 cm) into the ground, and only if there is no danger of encountering underground utilities. If there is any concern with the presence of underground utility infrastructure, stop and consult local utilities company.
- Check clearance with utility infrastructure such as overhead lines before raising arm.
- DO NOT leave the operator's seat if any part of the implement or vehicle contacts electric lines or cables.

## General Safety Requirements (Cont'd)

### Raised Attachment

#### WARNING

Take measures to ensure safety around a raised attachment or raised arm on the attachment.

- Do not enter the area under an attachment on a raised front end loader.
- Do not enter the area beneath raised rock picker arms.
- Raised rock picker arms can fall unexpectedly, causing death or serious injury.
- Lower the front end loader and the rock picker arms to the ground, de-pressurize the implement, engage parking brake, shut off engine and remove key before servicing.
- Use the locking pins on the rock picker arms when performing maintenance on picker. Refer to the instructions in this manual.

## Hydraulic Safety

### WARNING

Contact with high pressure fluids may cause fluid penetration and burn hazards. Fluid that is under pressure can penetrate body tissue. Fluid penetration can cause serious injury and possible death. If fluid is injected into the skin, seek medical attention immediately!

- Always wear eye protection when working on hydraulic system to avoid injury to the eyes.
- The hydraulic system is under high pressure. Make sure all lines and fittings are tight and in good condition. These fluids escaping under high pressure can have sufficient force to penetrate skin and cause serious injury.
- Never check for leaks by using any part of your body to feel for escaping fluid.
- To prevent serious personal injury from escaping high pressure fluid, never attempt to inspect, service or disassemble any part of the hydraulic system until all pressure has been relieved from the system.

## California Proposition 65 Warning

### WARNING

*This product can expose you to Mineral Oil, which is known to the State of California to cause cancer. For more information, go to [www.p65warnings.ca.gov](http://www.p65warnings.ca.gov).*

A decal with this warning statement is adhered to the machine. If the decal should become worn or missing, replace immediately.

## Safety Labels

Your rock picker comes equipped with all safety labels in place. These safety labels are designed to help you safely operate your implement. They inform you about possible hazards associated with the normal operation or foreseeable misuse of the product and how to properly avoid those hazards to prevent physical injury or death. The operator of the implement is required to read and follow their directions.





- Keep all safety labels clean and legible.
- Replace all damaged or missing labels.
- New equipment installed during repairs may require replacement safety labels to be affixed to the replaced part, if missing, as specified by TerraClear.
- Contact TerraClear to order replacement safety labels and decals using part number 00002541.
- Refer to this section for proper label placement. When installing new labels:
  - Clean surface with soapy water or surface cleaning solution and allow to dry.
  - Peel backing from label, carefully center and place label in proper location ensuring no creases or air pockets.
  - Press label firmly onto the surface and use a straight edge to smooth the label on the implement for a secure adhesion.

*(See safety label details on the following two pages.)*

## Safety Instructions



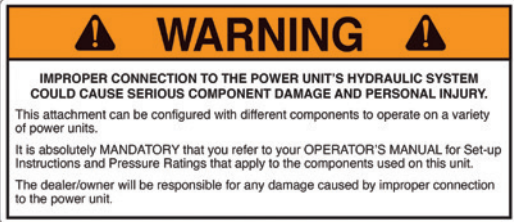

### Safety Labels (Cont'd)

**NOTE:** The following two pages show only safety labels and describe their location on the machine. For other decals (e.g., logo decals, grease point labels, serial number tag, etc.), see page 8.





Label	Name	Location(s)
	Warning - Pinch Point. (Keep hands clear)	<ul style="list-style-type: none"> <li>Left side of carriage.</li> <li>Right side of carriage.</li> </ul>
	Warning - High Pressure Hydraulics. (Release can cause serious injury or death.)	<ul style="list-style-type: none"> <li>On the valve cover plate, rear left side of the rock picker.</li> </ul>
	Warning - Improper Connection To The Power Unit's Hydraulic System Could Cause Serious Component Damage And Personal Injury.	<ul style="list-style-type: none"> <li>On the valve cover plate, rear left side of the rock picker.</li> </ul>
	Warning - Rotating Parts Hazard. (Can cause serious injuries or death. Do not operate machine without shields attached.)	<ul style="list-style-type: none"> <li>Right side of paddle assembly.</li> </ul>
	Warning - Crush Hazard. (Avoid serious injury or death. Stay clear of moving mechanism.)	<ul style="list-style-type: none"> <li>On the valve cover plate, rear left side of the rock picker.</li> </ul>

## Safety Instructions

### Safety Labels (Cont'd)

Label	Name and Part No.	Location(s)
	Danger - Crush Hazard. (Stay clear.)	<ul style="list-style-type: none"> <li>On each side of the bucket, on the carriage rail caps.</li> </ul>
	Warning - Pinch Point. (Keep Hands Clear)	<ul style="list-style-type: none"> <li>On the sideshift cylinder located at the rear of the rock picker.</li> </ul>
	Warning - Skin Puncture Hazard. (Hydraulic Lines. Protect hands and body from high pressure fluids.)	<ul style="list-style-type: none"> <li>On the sideshift cylinder located at the rear of the rock picker.</li> </ul>
	Warning - To prevent serious injury or death from moving parts. (- Keep hands, feet and clothing away from moving parts. - Close all guards and shields before operating machinery.)	<ul style="list-style-type: none"> <li>On the sideshift cylinder located at the rear of the rock picker.</li> </ul>
	Warning - Product Exposure; California Prop 65. (This product can expose you to Mineral Oil.)	<ul style="list-style-type: none"> <li>On the sideshift cylinder located at the rear of the rock picker.</li> </ul>

Decals

Label	Name	Location(s)
	50-hour Grease Point 100-hour Grease Point	<ul style="list-style-type: none"> <li>Adjacent to each grease zerk on the rock picker. See "Lubrication" on page 19 for locations.</li> </ul>
	TerraClear Logo Decal	<ul style="list-style-type: none"> <li>On the top front edge of the rock guard frame.</li> <li>On the rear side of the carriage, beneath the rock guard.</li> </ul>
	FEMA - Seal of Quality	<ul style="list-style-type: none"> <li>Rear side of the rock picker, to the left of the universal mount.</li> </ul>
	Made in USA	<ul style="list-style-type: none"> <li>Rear side of the rock picker, to the left of the universal mount.</li> </ul>
	American Flag	<ul style="list-style-type: none"> <li>On the outer side of each arm.</li> </ul>

Serial Number Tag

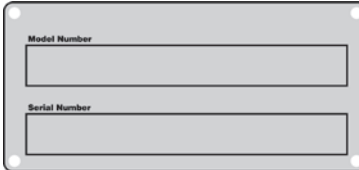
Tag	Name	Location(s)
	Serial Number Tag  <i>NOTE: Tag not included in safety label and decal kit.</i>	<ul style="list-style-type: none"> <li>Rear side of the rock picker, to the left of the universal mount.</li> </ul>

TC100 Rock Picker Component Identification

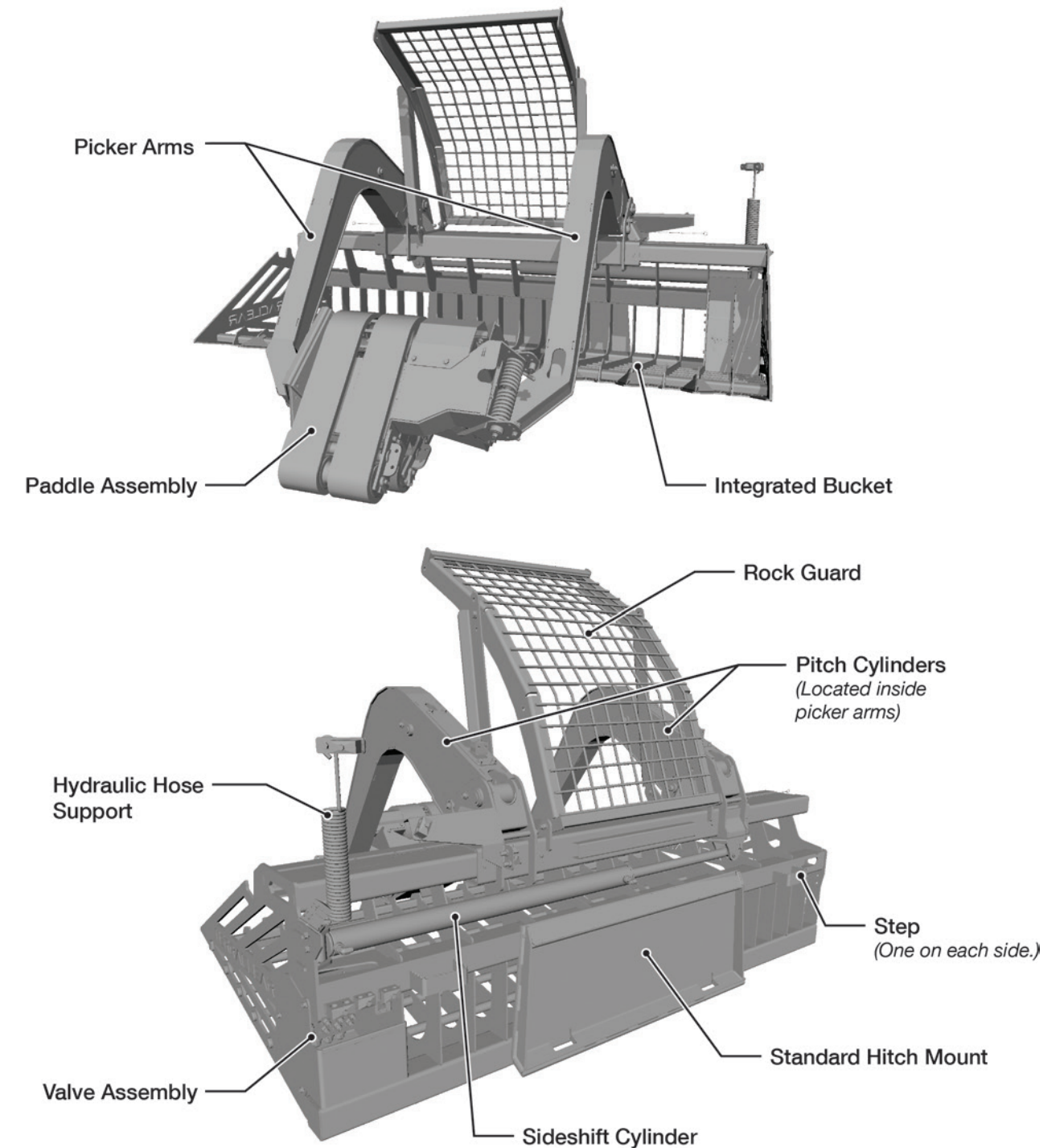

**NOTE:** Hydraulic hoses not shown for clarity.

## TC100 Rock Picker Functions

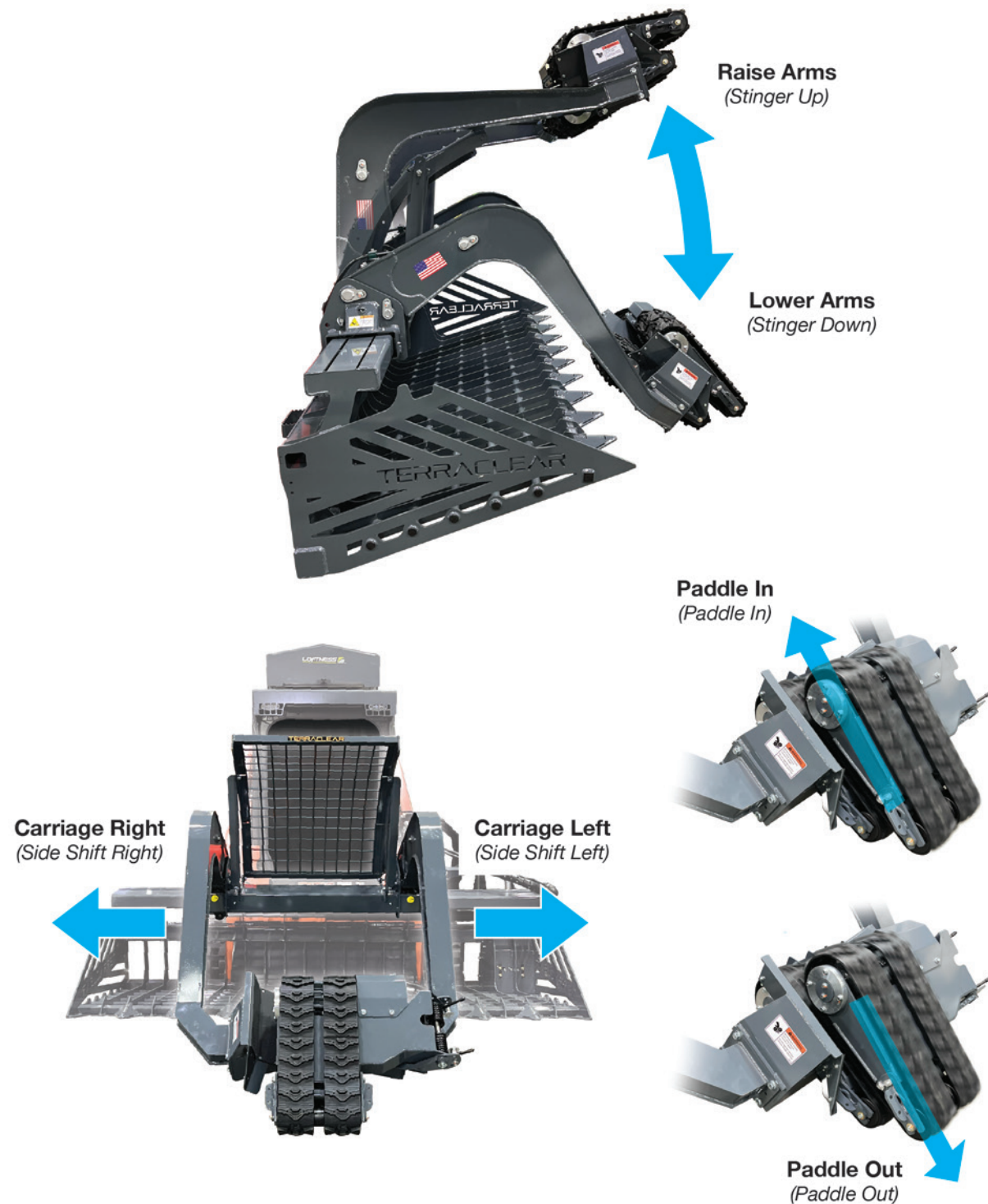

## Setting Up Auxiliary Control Connector

Due to variations in connector designs among track loader manufacturers, the Deutsch connector on the rock picker wiring harness is provided unpinned and must be pinned, along with some minor harness assembly, before installation.

**IMPORTANT:** Become familiar with the TC100 Rock Picker functions as shown on page 10. This will help you determine which controls in the track loader you will want to use.

**NOTE:** An example of pinning the loader harness for a Bobcat® T770 compact track loader is used for this procedure. As your loader make and model could be different, use this as a guide only to help understand how to pin the loader harness for your loader.

1. Start the track loader.
2. Locate the female 14-pin auxiliary control connector on the loader.

*EXAMPLE: Bobcat® T770 compact skid loader*

The diagram shows two joysticks from a Bobcat T770. The left joystick has buttons labeled G and H. The right joystick has buttons labeled D, C, E, and F. A yellow button is visible at the bottom of the right joystick.

Function	Pin
Ground (OV)	B
Side Shift (SS) Right	C
Side Shift (SS) Left	D
Paddle Out	E
Paddle In	F
Stinger Up	G
Stinger Down	H

3. Operate the loader joystick controls and use a multimeter (or similar diagnostic tool) to identify and verify each corresponding pin/socket on the connector.

Document each pin/socket in relation to the joystick controls.

Determine which joystick control will be used for each function on the rock picker.

**NOTE:** While "B" is usually the ground pin, always refer to your specific machine or system's wiring diagram to ensure accuracy.

4. Turn off the track loader when all pins have been identified.

## Installing the Harness Wiring into the Plug

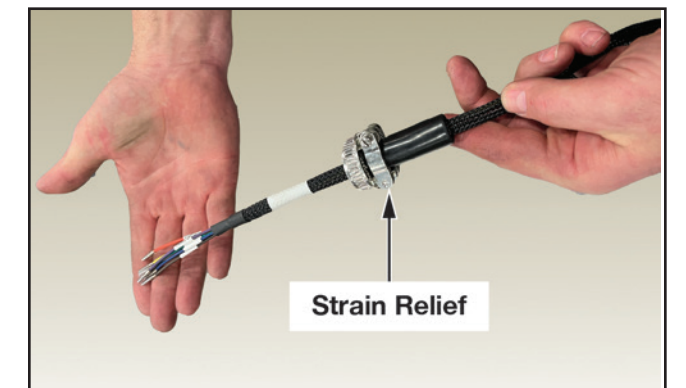

1. Install the strain relief assembly onto the end of the harness as shown above.

**NOTE:** The pins on the loader harness are factory-crimped, and the wire ends are pre-labeled for easier identification.

*EXAMPLE: Bobcat® T770 compact skid loader*

The diagram shows a 14-pin Deutsch connector with various pins labeled. Colored lines connect the labels to the corresponding pins: D (blue), E (black), F (purple), G (yellow), H (orange), C (green), and B (black).

D	Side Shift (SS) Left	E	Paddle Out
C	Side Shift (SS) Right	F	Paddle In
G	Stinger Up	H	Stinger Down
B	Ground (OV)		

2. Inserting one of the wire/pin ends through the corresponding hole in the plug. Push the wire through until you hear the pin click into place.

*(Procedure continued on following page.)*

### Setting Up Auxiliary Control Connector (Cont'd)

#### Installing the Harness Wiring into the Plug (Cont'd)

- Repeat the process until all seven pins are inserted and secured in the plug.
- Secure the strain relief onto the plug and tighten the clamp hardware.

#### Connecting the Harness to the Rock Picker

Once the harness has been pinned and assembled it can be connected to the rock picker.



- Connect the 8-Pin end of the harness to the female connector on the valve as shown above, located on the rear left side of the rock picker.
- Open the hose wrap, secured with a hook-and-loop seal, and route the wiring harness alongside the hydraulic hoses. Ensure sufficient slack is provided for connection to the track loader.
- Once complete, re-seal the hose wrap.

### Attaching and Detaching the Rock Picker

#### Attaching

The TerraClear TC100 Rock Picker is compatible with any track loader equipped with an auxiliary hydraulic system that provides a minimum flow of 18 GPM, as well as a standard compact track loader mounting plate.

- Raise the locking pins on the track loader mounting plate.
- Ensure the rock picker and track loader are positioned on level ground.

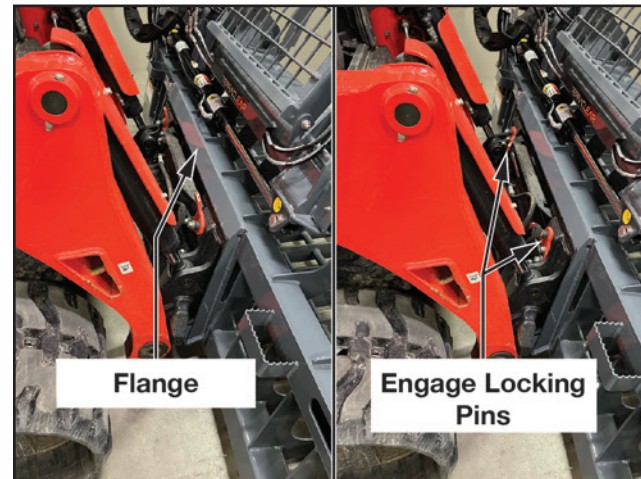

- Align the track loader with the rock picker mount. Tilt the loader mounting plate forward, drive forward, and hook the top edge of the mounting plate under the top flange on the rock picker mounting plate.
- Tilt the loader mounting plate back until the rock picker mounting plate is firmly against the loader. Do not lift the rock picker off the ground.
- Use the quick-coupler switch on the track loader to engage the locking pins.

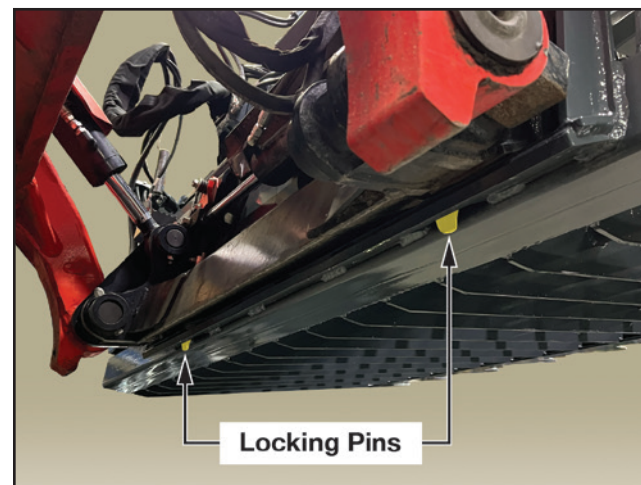

- Raise the rock picker and verify the locking pins are properly set in the rock picker mounting plate.
- Lower the rock picker and turn off the track loader.

### Attaching and Detaching the Rock Picker (Cont'd)

#### Hydraulic and Harness Connections



**NOTE:** Ensure all quick connect couplers are clean before attaching to auxiliary hydraulic supply ports.

- Connect the hydraulic lines to the standard auxiliary hydraulic supply ports by following the standard auxiliary hydraulics connection procedure in your track loader operator's manual.
- Connect the electrical harness to the auxiliary electrical port on the track loader.
- Visually inspect all hydraulic connections for leaks or loose fittings.

#### **WARNING**

Never use your hands to check for hydraulic leaks. Hydraulic fluid under pressure can cause serious injury, including skin penetration or other bodily harm. Always use a piece of cardboard or a cloth to detect leaks, and ensure the system is depressurized before inspection.

#### Detaching

To detach the TC100 Rock Picker from the track loader, make sure the unit is on level ground.

- Ensure that the bucket is empty.

**IMPORTANT:** If the bucket is not empty, do not detach the implement.

- Lower the rock picker arms until the paddle assembly is in contact with the ground.

- Turn off the track loader.
- Disconnect the wiring harness from the auxiliary electrical port on the track loader.

**NOTE:** When disconnecting the hydraulic lines from the auxiliary hydraulic supply ports on the track loader, it is good practice to push in the quick couplers first to relieve the pressure in the hydraulic system.

- Read the note above, then disconnect the hydraulic hoses.
- Secure the hydraulic lines and harness onto the rock picker, ensuring the hose ends and wiring harness connector are clear of dirt or debris.
- Turn on the track loader.
- Detach the rock picker backing plate from the track loader by reversing steps 3 through 5 in the "Attaching" procedure found on page "Attaching" on page 12, or follow the detachment procedure in your track loader operator's manual.

#### Startup

Before each use of the rock picker, conduct a thorough inspection of the machine. If any of these items are not sound, do not continue with use until resolved.

- Inspect all bolts for tightness.
- Inspect paddle system for tightness, tears, and any lodged items.
- Inspect for any cracks in the steel.
- Inspect bearings.

**IMPORTANT:** If you have any questions regarding the instructions, safety requirements, or need assistance in resolving any issues, please contact TerraClear Support at +1 (425) 274-2905.

#### Starting

For safety, ensure the area is clear of obstacles, debris, and bystanders before starting the track loader.

To start the rock picker, engage the standard auxiliary hydraulics in the direction that provides pressure to the implement's pressure lines, as directed in your track loader operator's manual.

## Set-up Instructions

### Testing

Once all assembly, installation, and attachment steps are complete, it is essential to perform a test to verify that the rock picker is operating correctly.

Follow the Startup procedure on page 13 and inspect for any signs of leaking fittings.

**IMPORTANT:** *During the testing procedure, if any issues arise or are suspected, lower the implement arm until the paddle assembly is in contact with the ground, shut down track loader immediately, and service.*

*If for any reason you do not understand the instructions or safety requirements for servicing, contact TerraClear Support.*

If any of the rock picker functions are not operating as expected, review the assembly and installation procedures. If all steps were followed, contact TerraClear Support.

### Shutdown

To shut down the rock picker, disengage the auxiliary hydraulics as directed in your track loader's operator's manual.

Shut down the track loader as directed in your track loader operator's manual.

To detach the rock picker, see "Detaching" on page 13 to properly disconnect the rock picker.

## Operating Instructions

### Operating Instructions

#### Guidelines

To safely and effectively operate the rock picker, follow the guidelines below.

- Follow proper Startup and Shutdown procedures as outlined in the "Set-Up Instructions" section.
- Always follow the operation instructions of your track loader, found in the track loader's operator's manual.
- Use the joystick controls as determined in "Setting Up Auxiliary Control Connector" on page 11.

#### Rock Picking

When traveling, use the bucket tilt functionality of your track loader to ensure that the bucket does not drag on the ground.

Raise the rock picker arms when traveling between rocks to avoid collision with objects or the ground.

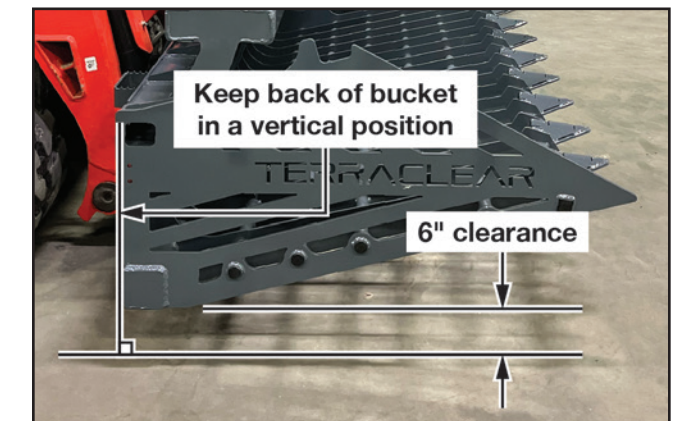

Keep the bucket approximately 6 in. (15.25 cm) above ground (or above the bottom of the loader tracks) and the back of the bucket in a vertical position during field travel and operation.

1. With the track loader running, turn on the constant auxiliary hydraulic flow to the picker.
2. Approach the target rock slowly, positioning the paddle assembly at the designated location for loading the rock into the bucket.

*(Procedure continued on following page.)*

### Controls and Functions

Once the set-up and testing is complete, the TC100 Rock Picker is now ready for operation.

Take the time to familiarize yourself with all the controls and functions in an open area, and get comfortable with the machine before operating it in a field environment

### Break-in Time

After 50 hours of operation, the tension in the belts will need to be tightened. The belt tensioner tabs are factory-set on Stage 1 and should be adjusted to Stage 2. Refer to "Belt Tensioning and Replacement" on page 20 for instructions on adjusting the belt tension.

### Operation Safety

#### WARNING

Follow safe practices while operating the rock picker.

- Carry the rock picker low.
- Travel slowly and avoid slopes.
- Avoid sharp turns and sudden movements on slopes.
- Do not raise the bucket on slopes.
- Do not exceed the load capacity of the host equipment.
- Follow all safety guidelines for your compact track loader, outlined in the loader operator's manual.
- Only operate using a compact track loader with a closed cab.
- Do not operate the rock picker without the rock guard properly assembled.
- Inspect surroundings for bystanders and other equipment before dumping rocks.

**IMPORTANT:** *Ensure that the track loader's windshield is equipped with impact-resistant glass or an appropriate protective guard when operating the rock picker. TerraClear is not responsible for any damage to the windshield, or any other part of the track loader, caused by flying rocks or debris.*

## Operating Instructions (Cont'd)

### Rock Picking (Cont'd)



- Shift the rock picker arms side-to-side when loading rocks to achieve optimal distribution weight throughout the bucket.



- Simultaneously lower the rock picker arms until the top paddle makes contact with the top of the rock.



- Engage the paddle intake.

- When the rock has entered the paddles, continue the paddle intake while raising the rock picker arms. The rock will be conveyed into the bucket.

**NOTE:** Reverse the direction of the paddle to clear any rocks from the paddles that may have difficulty loading.

### Dumping

Raise the rock picker arms to the maximum height before using the track loader to dump the rocks from the bucket.

**NOTE:** Consult your track loader operator's manual for information on how to raise and tilt the bucket. Pay close attention to safety guidelines for doing so, particularly on slopes.

### Transporting

#### Road Travel

#### **CAUTION**

Always comply with all federal, state and local laws when traveling on public roads whether at night or during the day. Use accessory lights and devices for adequate warning to operators of other vehicles.

Raise the rock picker high enough so that the bucket can not come in contact with the ground during travel. Ensure the operator has a clear vision of the path ahead.

Disengage hydraulics.

Select a safe ground travel speed when transporting from one area to another. Reduce ground speed when turning.

#### Hauling

When transporting the rock picker on a trailer or on a truck, make sure the machine is properly and safely tied down and secure.

#### **WARNING**

Failure to secure the rock picker when transporting could result in serious injury or death to those in surrounding vehicles and/or bystanders.

## Troubleshooting

PROBLEM	CAUSE	SOLUTION
Picker functions not responding.	Auxiliary hydraulic functions down	Consult your track loader operator's manual.
	Electrical failure.	If connectors are loose, reconnect. If signal pins from the track loader are malfunctioning, refer to your loader operator's manual. If problem persists, call TerraClear support.
Belts not turning.	Debris.	With the track loader turned off, remove the debris from the belts.
	Bearing failure.	With the track loader turned off, replace the bearing. Contact TerraClear for replacement bearing and procedure.
	Derailment.	Re-position belts. See belt replacement instructions in the maintenance section for more information.
	Motor failure.	Contact TerraClear for replacement part and procedure.
Rocks slipping from the paddles.	Broken torsion spring or bearing failure.	Contact TerraClear for replacement part and procedure.
Hydraulic leak.	Loose fitting.	Immediately shutdown and clear all bystanders. Tighten fittings.
	Ruptured hose.	Immediately shutdown and clear all bystanders. Replace hose.
	Valve failure.	Immediately shutdown and clear all bystanders. De-pressurize implement. Inspect valve and replace valve parts. Contact TerraClear for parts and replacement procedure.
	Motor failure.	Immediately shutdown and clear all bystanders. De-pressurize implement. Replace motors. Contact TerraClear for parts and replacement procedure.

#### **WARNING**

Strictly follow all procedures outlined in "Belt Tensioning and Replacement" beginning on page 20 when performing maintenance on the paddle assembly. Tension in spring and/or an unsupported upper paddle can result in serious injury if instructions are not followed.

**General Maintenance**

**IMPORTANT:** Refer to “Maintenance Safety” on page 19 and become familiar with the safety rules before performing any maintenance or service on the rock picker.

To ensure efficient operation, you should inspect, lubricate, and make necessary adjustments and repairs at regular intervals. Parts that are starting to show wear should be ordered ahead of time, before a costly breakdown occurs and you have to wait for replacement parts. Keep good maintenance records, and adequately clean your rock picker after each use.

Proper lubrication is important. Too little lubricant will cause premature failure of a bearing. Too much lubrication usually causes high operating temperatures and early failure of seals. Follow all lubrication instructions and schedules included in this section.

**Maintenance Safety**

**⚠ WARNING**

- Do not perform maintenance activities while the track loader is on.
- Do not perform maintenance activities while hydraulic lines are under pressure.
- Do not walk beneath any part of the rock picker during maintenance or otherwise.
- Do not disassemble the paddle assembly; tension in spring can cause serious harm.

TERRACLEAR

**Maintenance Schedule**

Conduct the following maintenance procedures at the prescribed frequency for maximum longevity and safety.

PROCEDURE	FREQUENCY
Check belt tension and condition.*	Daily
Lubrication <i>(See pages 19 and 20.)</i>	Every 50-100 hours of operation
Apply dry graphite spray to coat T-bar in carriage.	Every 100 hours of operation
Check and re-torque all bolts and fittings.	Every 100 hours of operation

\* Add tension or replace belts when loosening of belts, or wear, is noticeable. Also, belts must be re-tensioned at the 50-hour break-in period.  
*(See the belt tensioning and replacement procedure beginning on page 20.)*

**Lubrication**

**Grease Point Locations**

Use a #2 general purpose lithium based grease unless noted otherwise.

**NOTE:** Replace any broken or missing grease fittings. Be sure to clean fittings before greasing.

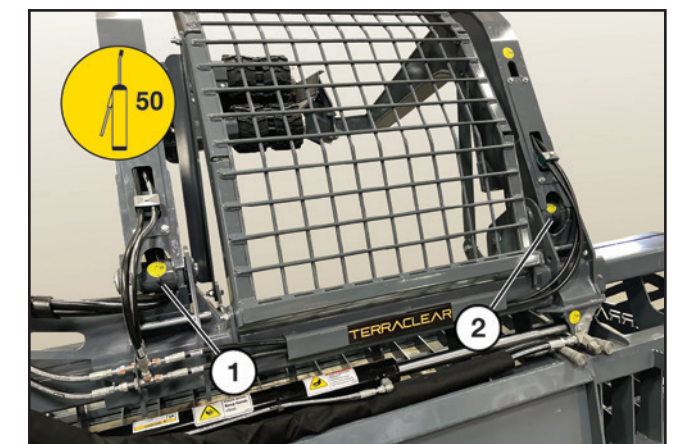

**Location:** Picker arm pivots (1, 2).  
**Frequency:** Every 50 hours of operation.

## Lubrication (Cont'd)

### Grease Point Locations (Cont'd)

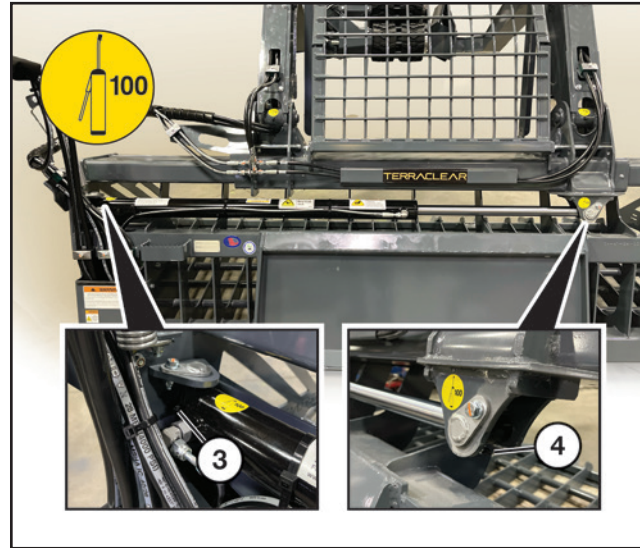

**Location:** Sideshift cylinder (3, 4).  
**Frequency:** Every 100 hours of operation.

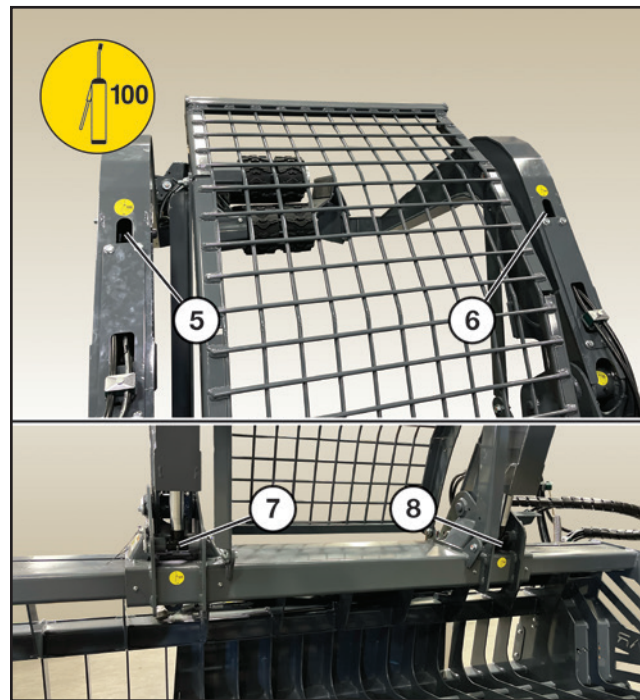

**Location:** Pitch cylinders (5, 6, 7, 8).  
**Frequency:** Every 100 hours of operation.

## Belt Tensioning and Replacement

1. Start the track loader.
2. Lower the rock picker arms so the paddles are resting on the ground.
3. Turn off the track loader.

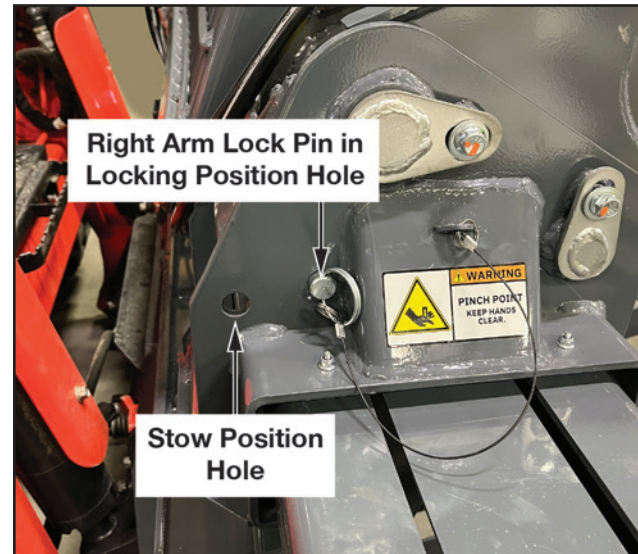

4. Move only the right arm lock pin from the stow position and insert it into the right side locking position hole.

**NOTE:** If the pin is obstructed by the rock picker arm, restart the track loader and lower the arms slightly further to allow the pin to pass through the opposite side of the picker arm bracket.

Turn off the track loader after the pin is secured in place.

### **CAUTION**

DO NOT insert the left arm lock pin at this point in the procedure. Inserting the pin may cause damage to both the pin and the rock picker.

(Procedure continued on following page.)

## Belt Tensioning and Replacement (Cont'd)

### Releasing Spring Tension



1. Use a leverage pipe/bar to stabilize the tension spring while simultaneously removing the bolt, washer, and shaft. Set the hardware aside.
2. Repeat the process for the other tension spring.

### Lower Paddle Belt Tensioning/Replacement



1. Remove the four flange bolts with nuts securing the right arm to the paddle assembly and set aside.
2. Ensure the right arm lock pin is in the lock position.
3. Start the track loader.

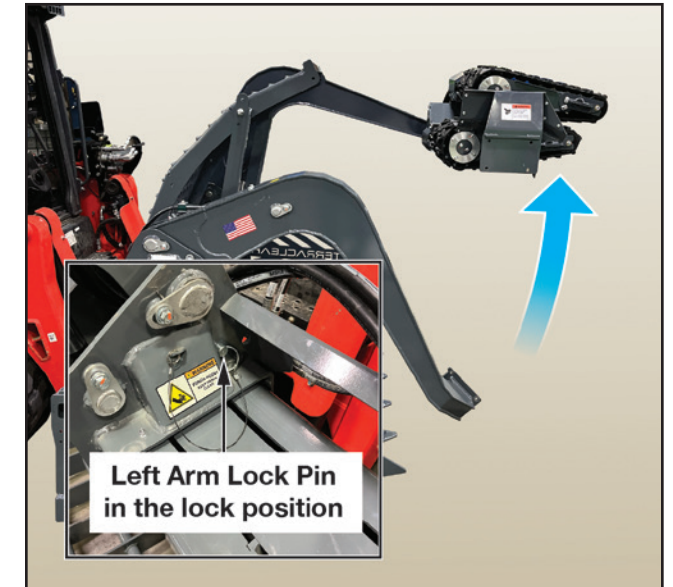

4. Raise the left rock picker arm so that the left arm lock pin can be inserted through the locking position hole.

Remove the locking pin from the stow position and insert it into the lock position.

5. Turn off the track loader.
6. Insert the left arm lock pin as shown above.

**NOTE:** If the pin is obstructed by the rock picker arm, restart the track loader and raise the arm slightly further to allow the pin to pass through the opposite side of the picker arm bracket.

Turn off the track loader after the pin is secured in place.

(Procedure continued on following page.)

Belt Tensioning and Replacement (Cont'd)

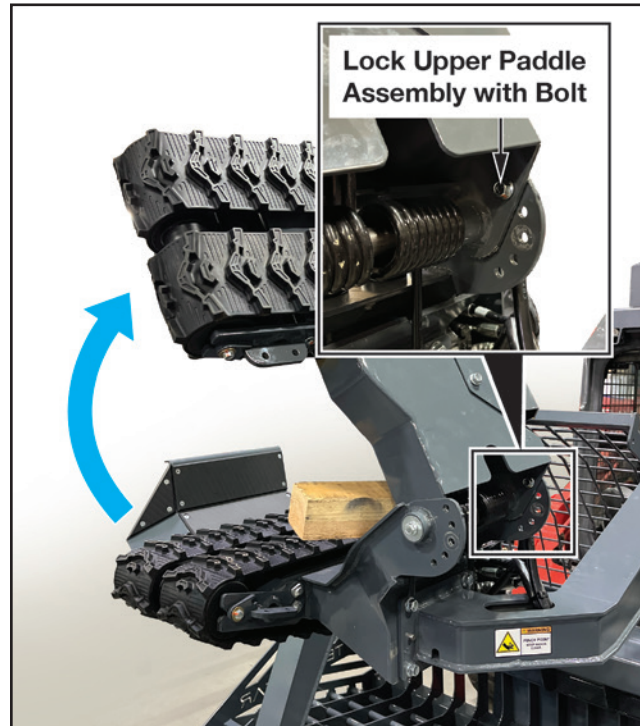

7. Pivot the upper paddle upwards and secure it in place by inserting one of the spring tension bolts, which was removed earlier, through the designated hole as shown in the image above.

Additional blocking is recommended, as shown above.

**WARNING**

**CRUSH HAZARD.** Failure to properly lock and secure the upper paddle in place during this procedure may cause the upper paddle to fall, resulting in serious injury.

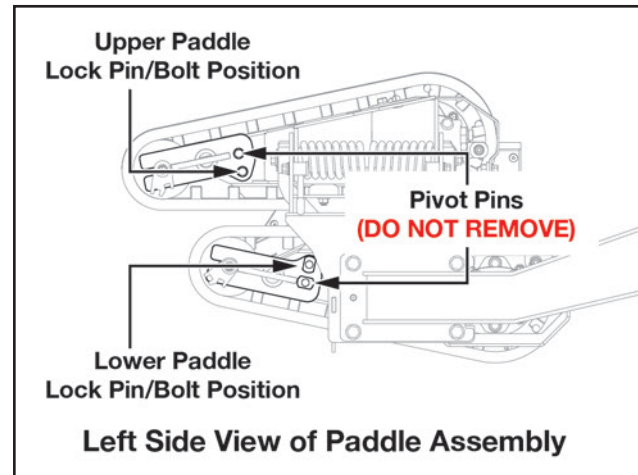

8. Locate the lock pin location(s) on the idler assembly shown above.

**NOTE:** The upper paddle assembly is also shown here to indicate its location when the upper paddle belt requires adjustment or replacement, helping you easily identify it during the process.

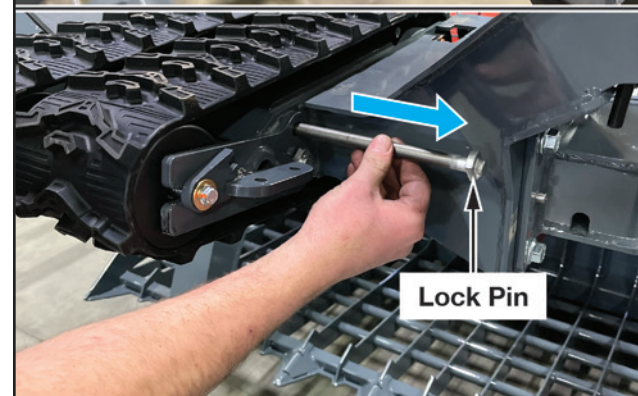
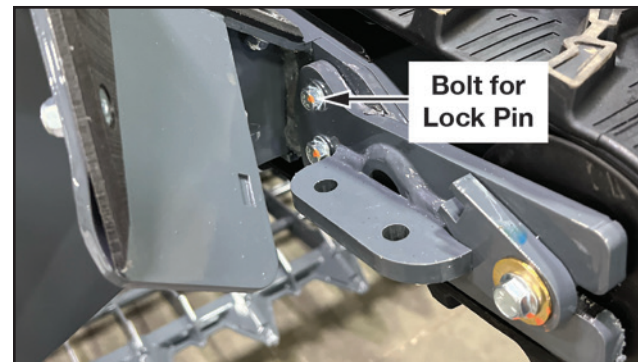

9. Remove the lock bolt securing the lock pin and slide the lock pin out. DO NOT remove the pivot pin.

(Procedure continued on following page.)

Belt Tensioning and Replacement (Cont'd)

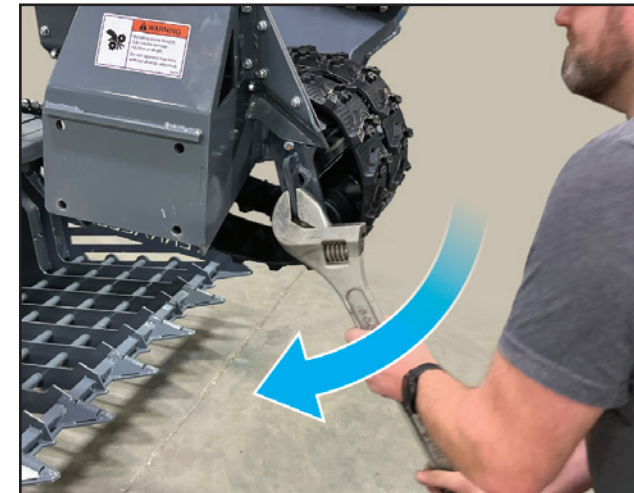

10. Using a large wrench as leverage, pivot the idler assembly to remove the load on the belt tension.



**NOTE:** Record the direction the belt tread, you will want to reinstall the belts in the same direction in a later procedure.

11. Slide the belts off of the lower paddle.

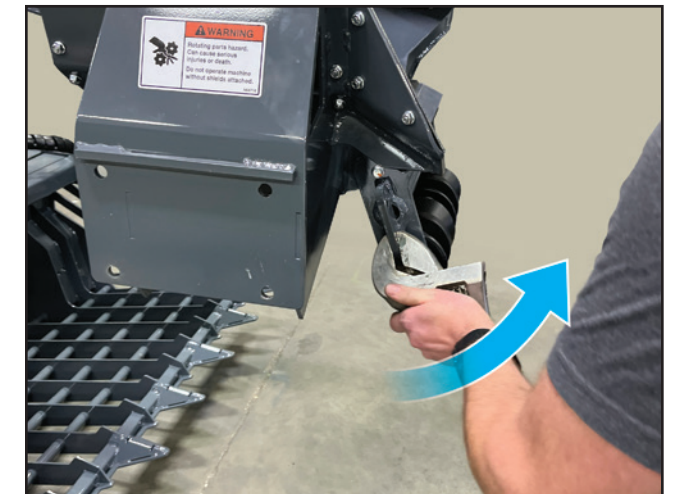

12. Pivot the idler assembly back into the load position.



13. Remove the bolt and washer from each end of the belt idler assembly and set aside.

(Procedure continued on following page.)

**Belt Tensioning and Replacement (Cont'd)**

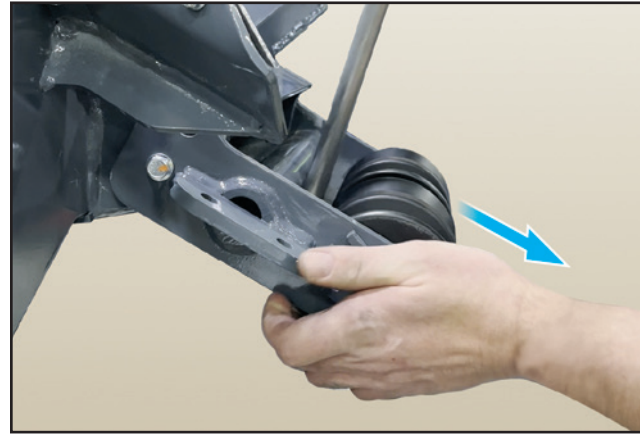

14. Slide the belt idler assembly out far enough to allow the tensioner tabs (right and left sides) to pivot. You may need to use a pry bar for assistance.
15. Step 15 involves setting the tensioner tabs. There are two separate procedures - one for setting the tabs if the same belt will continue to be used and only needs tensioning; and one for setting the tabs for installing a new belt.

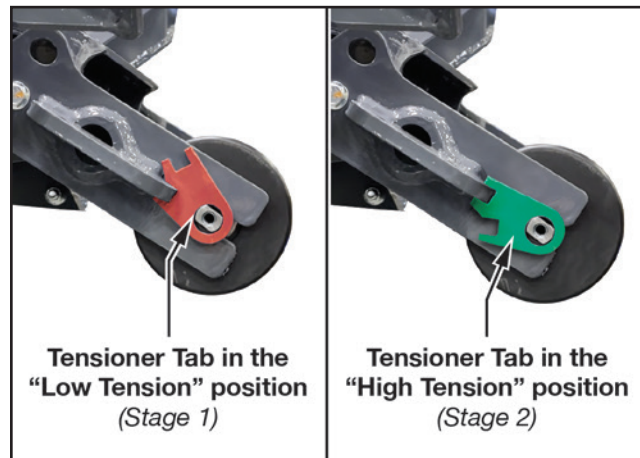

**To increase the tension for existing belts:** Reposition the tensioner tabs from the low tension position (Stage 1) to the high tension position (Stage 2). Make sure both tabs (right and left side) are set on Stage 2.

**NOTE:** This procedure should be performed at the 50-hour break-in period, or if the belts are beginning to stretch.

**When installing new belts:** Set the tensioner tabs to the low-tension position (Stage 1). Make sure both tabs (right and left side) are set on Stage 1.

16. After the tensioner tab positions have been set, make sure the belt idler assembly is pushed back in until the slot in the tensioner tab bottoms out.
17. Reinstall the bolts and washers securing the belt idler assembly.

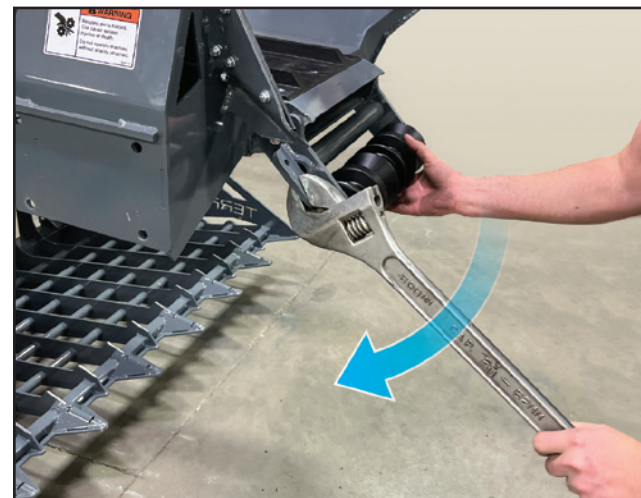

18. Pivot the idler assembly to the neutral (slack) position.

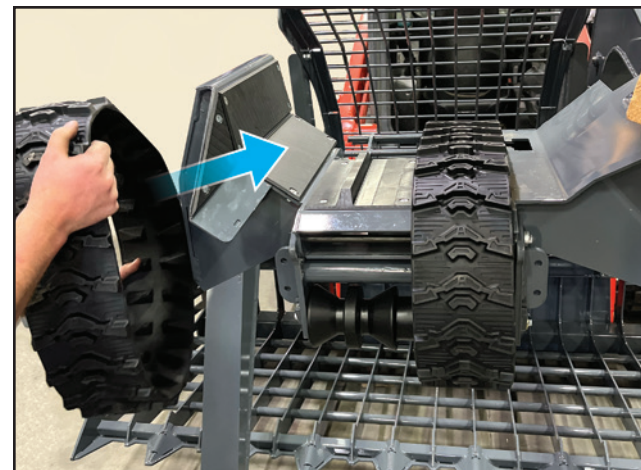

19. Install the belts. Make sure they align properly on the belt idler and that the belt tread is going in the same direction as recorded earlier.

*(Procedure continued on following page.)*

**Belt Tensioning and Replacement (Cont'd)**

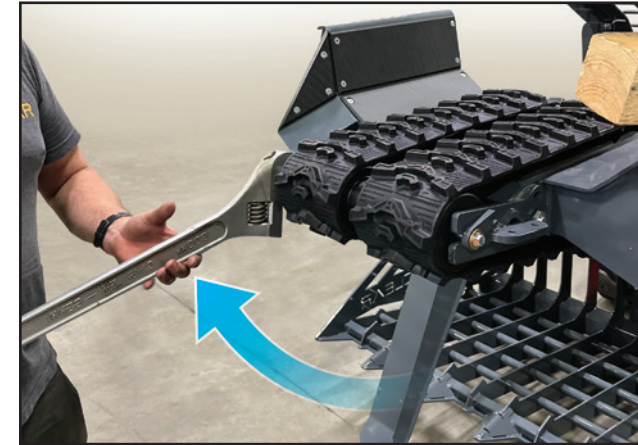

20. Pivot the idler assembly back into the load position, applying tension to the belts.

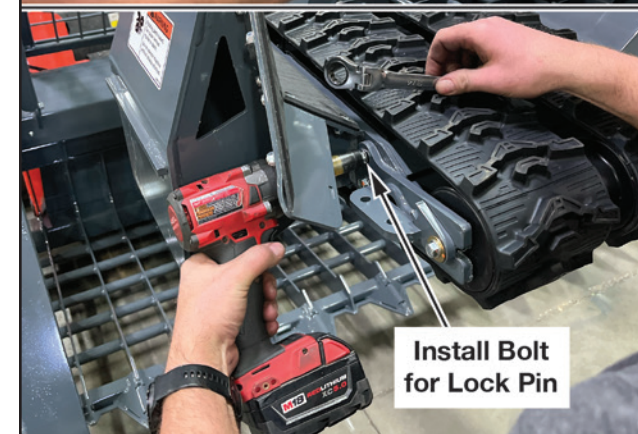

21. Reinstall the lock pin and secure with the bolt.

22. Remove the block of wood and the bolt holding the upper paddle in place. Carefully lower the upper paddle assembly back into position.

**Upper Paddle Belt Tensioning/Replacement**

The instructions for adjusting the belt tension and/or replacing the belts for the upper paddle are identical to the lower paddle. Follow steps 8 through 22 in “Upper Paddle Belt Tensioning/Replacement”, which begins on page 21; however, be aware that the upper paddle design is inverted.

**Setting Spring Tension**

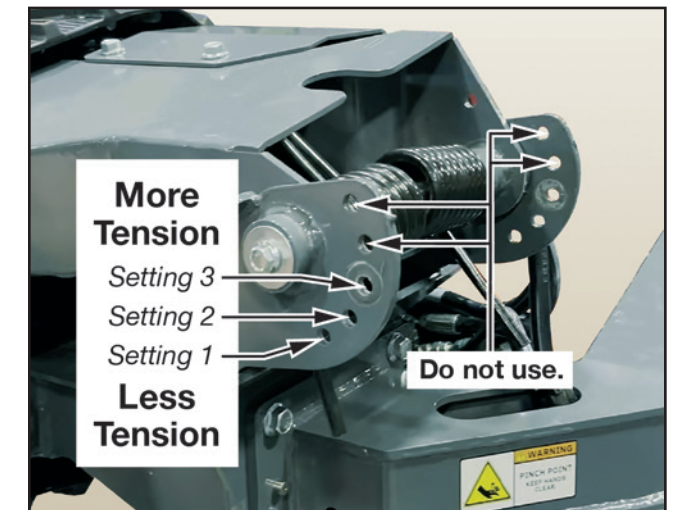

There are three spring tension positions on the upper paddle assembly. The tension is factory-set on the middle position (Setting 3). Position the shaft and hardware according to the desired tension setting.

**NOTE:** Settings 4 and 5 should not be used. Setting 5 is reserved for the bolt that locks the upper paddle assembly in place during the lower belt tensioning/replacement procedure.

**CAUTION**

For safety, and to facilitate the tensioning procedure, it is recommended that two people perform this procedure. Failure to do so could result in injury.

*(Procedure continued on following page.)*

Belt Tensioning and Replacement (Cont'd)



1. One person should use the leverage pipe/bar to apply sufficient force to the tension spring end, allowing the bolt, washer, and shaft to be reinstalled into the desired tension position by the second person.
2. Repeat the process for the other tension spring, making sure the shaft and hardware is installed in the same hole setting as the opposite tension spring shaft.

Recoupling Right Arm to the Paddle Assembly



1. Remove the left arm lock pin from the locking position and put it in the stow position.

**CAUTION**

Failure to remove the left arm lock pin from the lock position for this procedure may cause damage to both the pin and the rock picker when the arm is lowered.

2. Start the track loader.

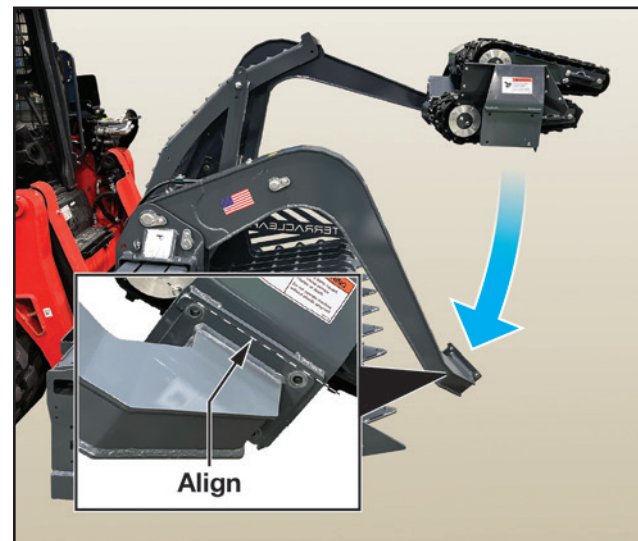

3. Lower the left arm until the paddle assembly aligns with the plate on the right arm. You may need to tilt or lift the bucket to help with alignment.
4. Turn off the track loader.

(Procedure continued on following page.)

Belt Tensioning and Replacement (Cont'd)



5. Reinstall the four bolts and nuts that secure the right arm plate to the paddle assembly. An alignment tool may be needed to assist with positioning.



6. Return the right arm lock pin to the stow position as shown above.

**CAUTION**

Failure to remove the right arm lock pin from the lock position and into the stow position may cause damage to both the pin and the rock picker when the picker arms are raised.

Rock Guard Adjustment

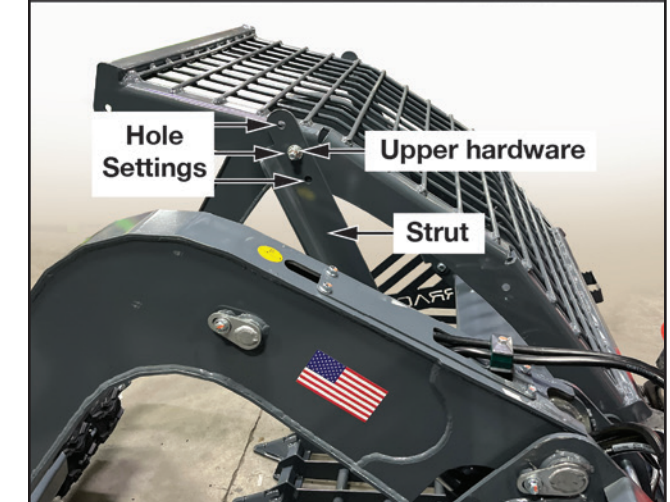
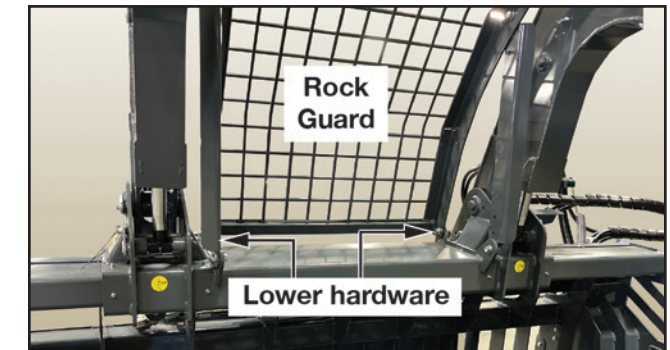

1. Loosen the lower nuts on the struts and the rock guard (both the left and right side).
2. Remove the upper bolts and nuts securing the struts to the rock guard (left and right side).
3. Adjust the struts and rock guard until the holes align for the desired angle/position
4. Reinstall the upper hardware and tighten. Retighten the lower nuts from step 1.

### Storage

#### End of Season

- Clean the entire rock picker thoroughly.
- Make a list of all worn or damaged parts and replace them.
- Paint all parts that are worn or rusted.
- Store the rock picker in a clean, dry area.
- Review the rock picker operator's manual.
- Secure hydraulic hoses in storage position.

#### Beginning of the Season

- Review the rock picker operator's manual.
- Tighten all bolts, nuts, and set screws. See "Torque Specifications" on page 44.
- Replace all damaged, worn or missing decals.
- Install the rock picker to a track loader and test for proper operation.

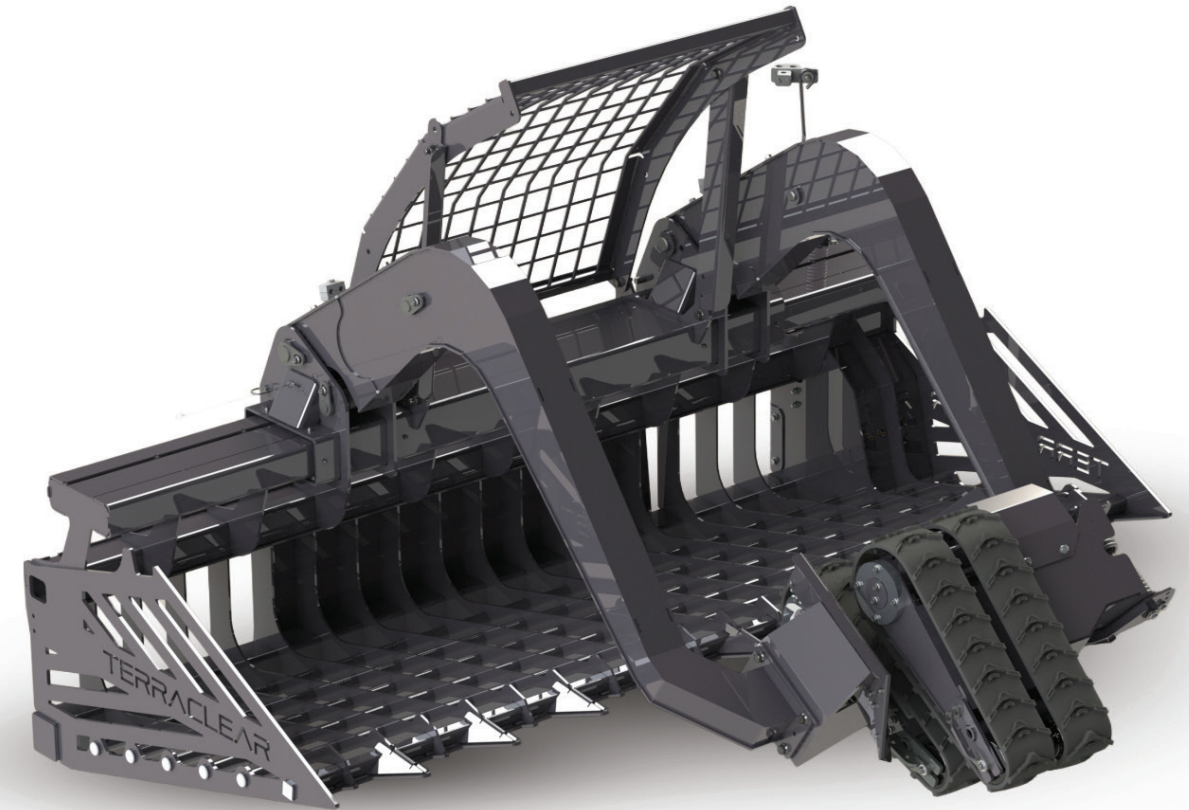

## PARTS IDENTIFICATION

Bucket, Valve Cover, Misc.

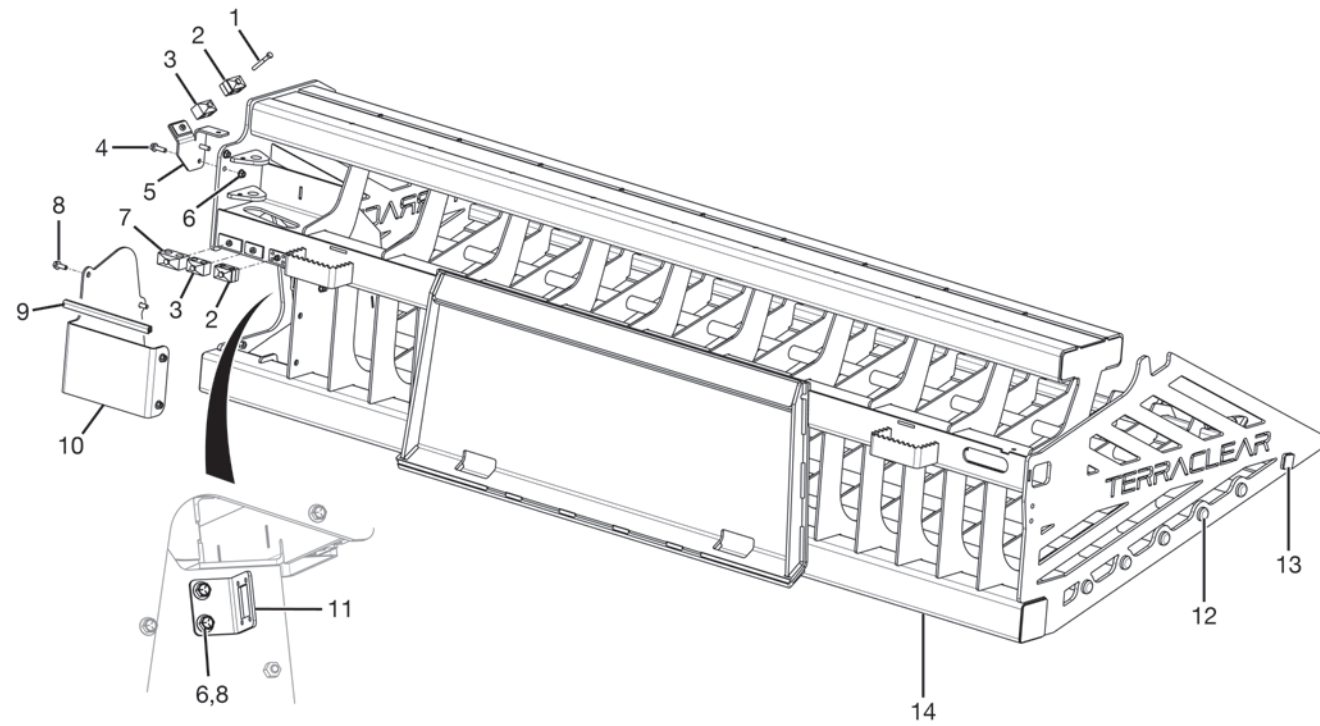

#	QTY.	PART #	DESCRIPTION
1	1	00002515	BOLT, 5/16" X 2-1/2" GRADE 5
2	2	00000125	CLAMP, 1/4 IN HYD DBL - 1/4IN ID
3	2	00000126	CLAMP, 3/8" DOUBLE HOSE
4	2	00002152	BOLT, 3/8" X 1-1/4" FLANGE
5	1	00002530	WELDMENT, HOSE & SPRING CLAMP
6	4	00002187	NUT, LOCK 3/8 FLANGE
7	1	00000152	CLAMP, DBL. 1/2" SUPP. HOSE
8	7	00002123	BOLT, 3/8 X 1 FLANGE
9	1	00002506	RUBBER, EDGE LOCK 10IN
10	1	00002119	PLATE, VALVE BOX COVER
11	1	00002416	PLATE, VALVE HARNESS HOLDER
12	9	00002402	PLUG, ROUND SNAP-IN PLASTIC
13	2	00002401	PLUG, SQUARE SNAP-IN PLASTIC
14	1	00002366	WELDMENT, P17 BUCKET

Sideshift Cylinder, with Hydraulic Support

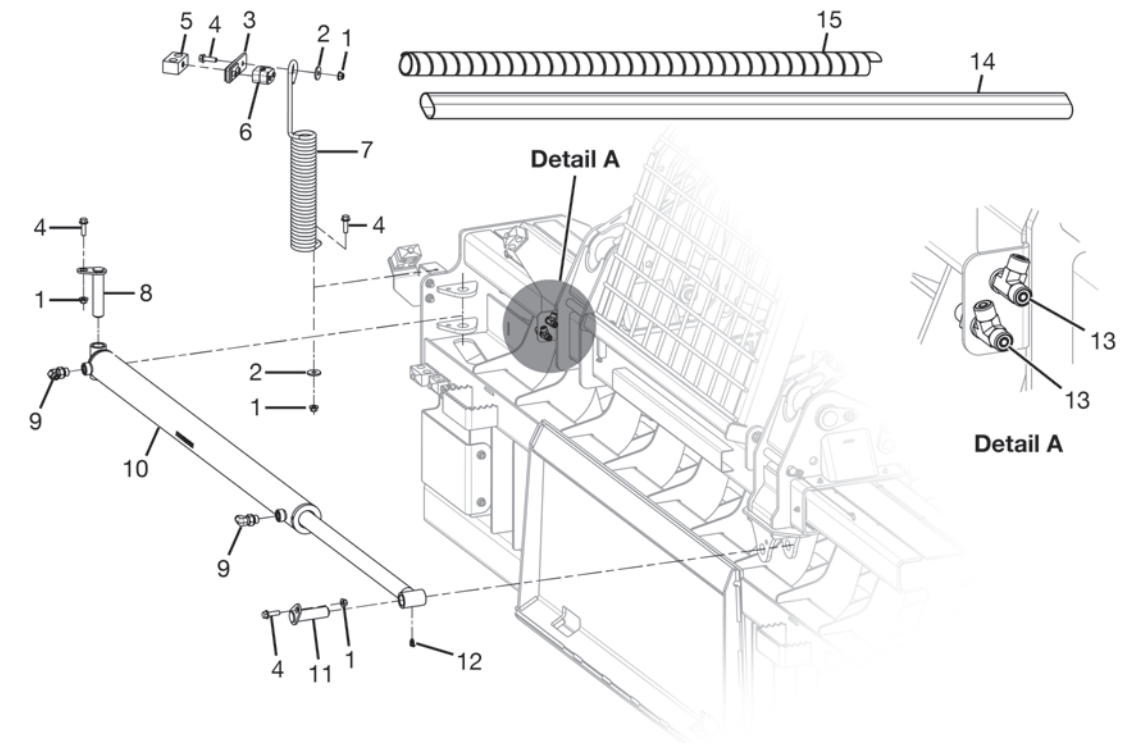

For hydraulic hoses, with part numbers, refer to the schematic on page 40.

#	QTY.	PART #	DESCRIPTION
1	4	00002187	NUT, LOCK 3/8 FLANGE
2	2	00001671	WASHER, SRPING TENSION HOLDER
3	1	00002512	WELDMENT, HOSE CLAMP & SPRING
4	4	00002152	BOLT, 3/8" X 1-1/4" FLANGE
5	1	00000152	CLAMP, DBL. 1/2" SUPP. HOSE
6	1	00002155	CLAMP, VIBRATION DAMP ROUTING
7	1	00002147	SPRING, HYDRAULIC HOSE SAVER
8	1	00002086	PIN, PIVOT W/TAB 1X4
9	2	00002048	ADAPTER, 90 DEG -4MORFS -8MOR
10	1	00001921	CYLINDER, 2.5 X 42 STROKE 3500PSI
11	1	00002087	PIN, PIVOT W/TAB 1 X 3
12	1	00002543	GREASEZERK, 90 DEG M6 X 1
13	2	00002152	BOLT, 3/8" X 1-1/4" FLANGE
47	1	00002505	SLEEVE, HOSE 2-1/2 X 72
46	1	00002504	WRAP, HOSE BLACK 53

Rock Picker Arms

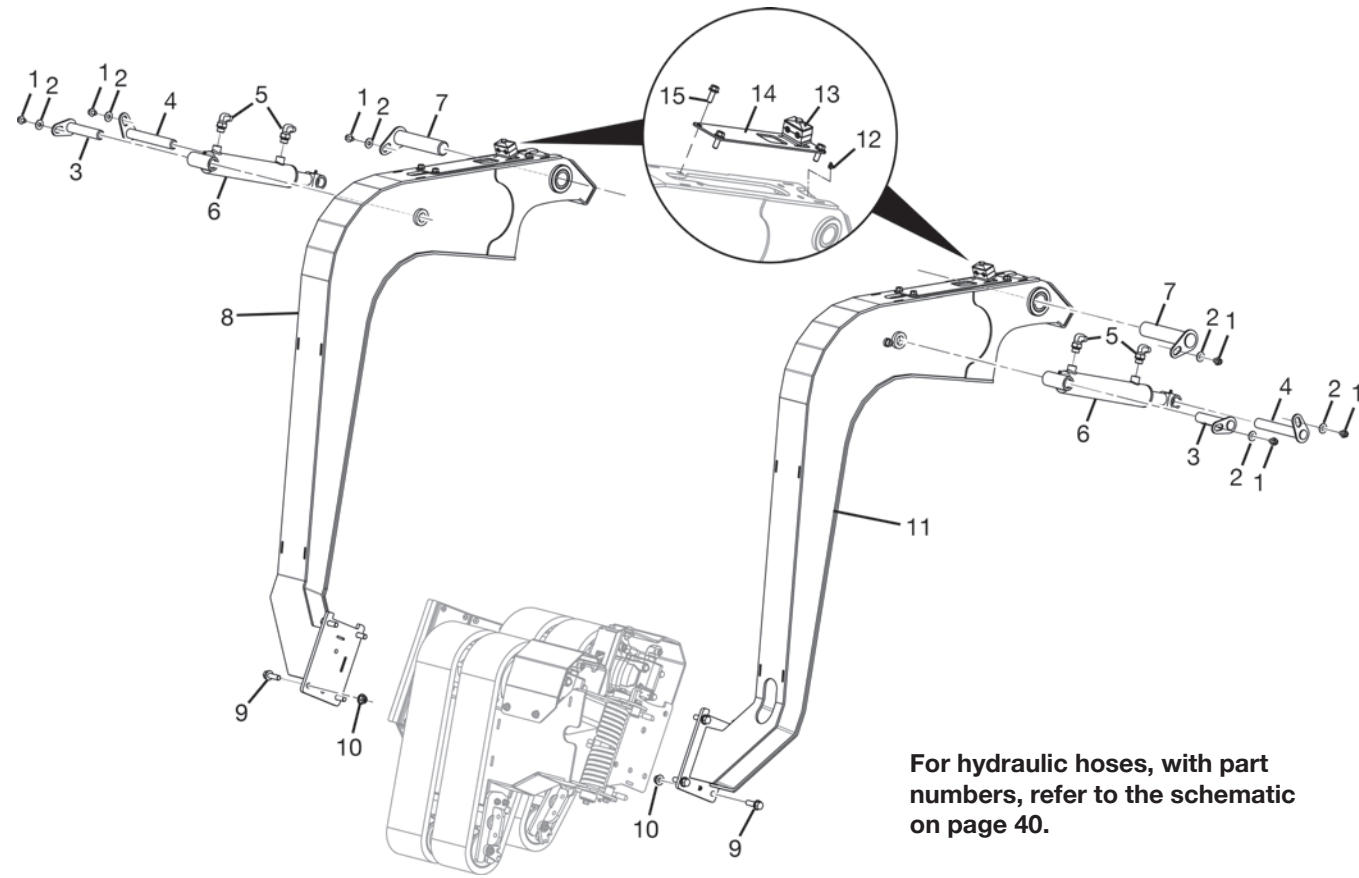

#	QTY.	PART #	DESCRIPTION
1	6	00002153	BOLT, 3/8 X 1/2 FLANGE
2	6	00002510	WASHER, FLAT 3/8"
3	2	00002289	PIN, PIVOT W/TAB 1 X 4.813
4	2	00002287	PIN, PIVOT W/TAB 1 X 6.938
5	4	00002048	ADAPTER, 90 DEG -4MORFS -8MOR
6	2	00002056	CYLINDER, 2 X 8 3000 PSI
7	2	00002390	PIN, PIVOT W/TAB 1.5 X 6.938
8	1	00002383	ASM, RIGHT ARM
9	8	00000062	BOLT, 1/2-13 X 1-1/2 FLG
10	8	00000061	NUT, LOCK 1/2 NYLOCK FLANGE
11	1	00002381	ASM, LEFT ARM
12	2	00002205	GREASE-ZERK, 1/4" SCREW-IN
13	2	00000125	CLAMP, 1/4IN HYD DBL - 1/4IN ID
14	2	00002346	CAP, ARM
15	8	00002123	BOLT, 3/8 X 1 FLANGE

Paddle Assembly

\* For a complete parts breakdown of the Upper Paddle Assembly, see page 34.

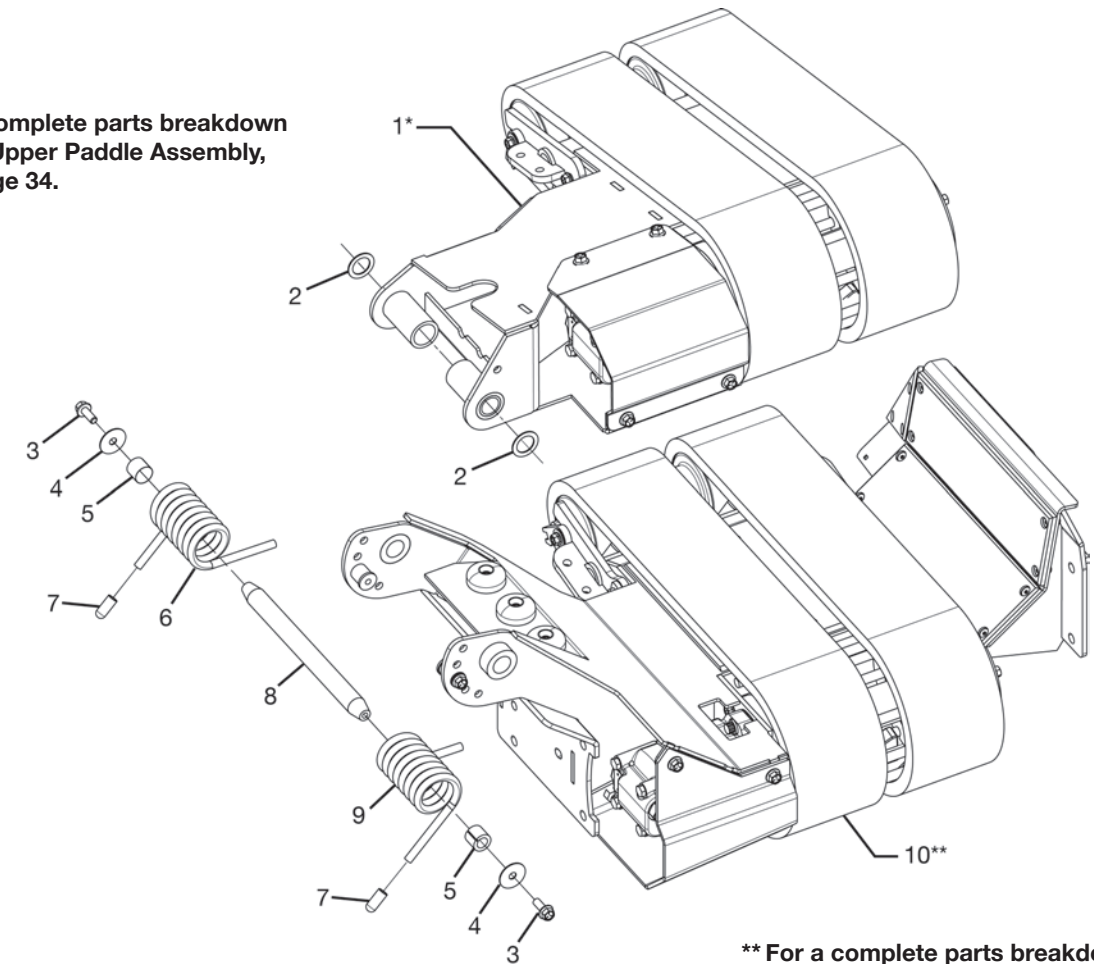

#	QTY.	PART #	DESCRIPTION
1	1	00002361	ASM, UPPER PADDLE
2	2	00002514	WASHER, 1" ID THIN SPACER
3	2	00002123	BOLT, 3/8 X 1 FLANGE
4	2	00002122	WASHER, FLAT 3/8 OVERSIZED PLATED
5	2	00001994	BUSHING, P17 EE TAPERED
6	1	00001968	SPRING, RAMP TORSION
7	2	00002525	CAP, GBU10 ROLLER HOOK SMALL
8	1	00001993	PIN, P17 EE TAPERED
9	1	00001673	SPRING, RAMP TORSION LEFT
10	1	00002360	ASM, P17 EE LOWER PADDLE

Upper Paddle Assembly

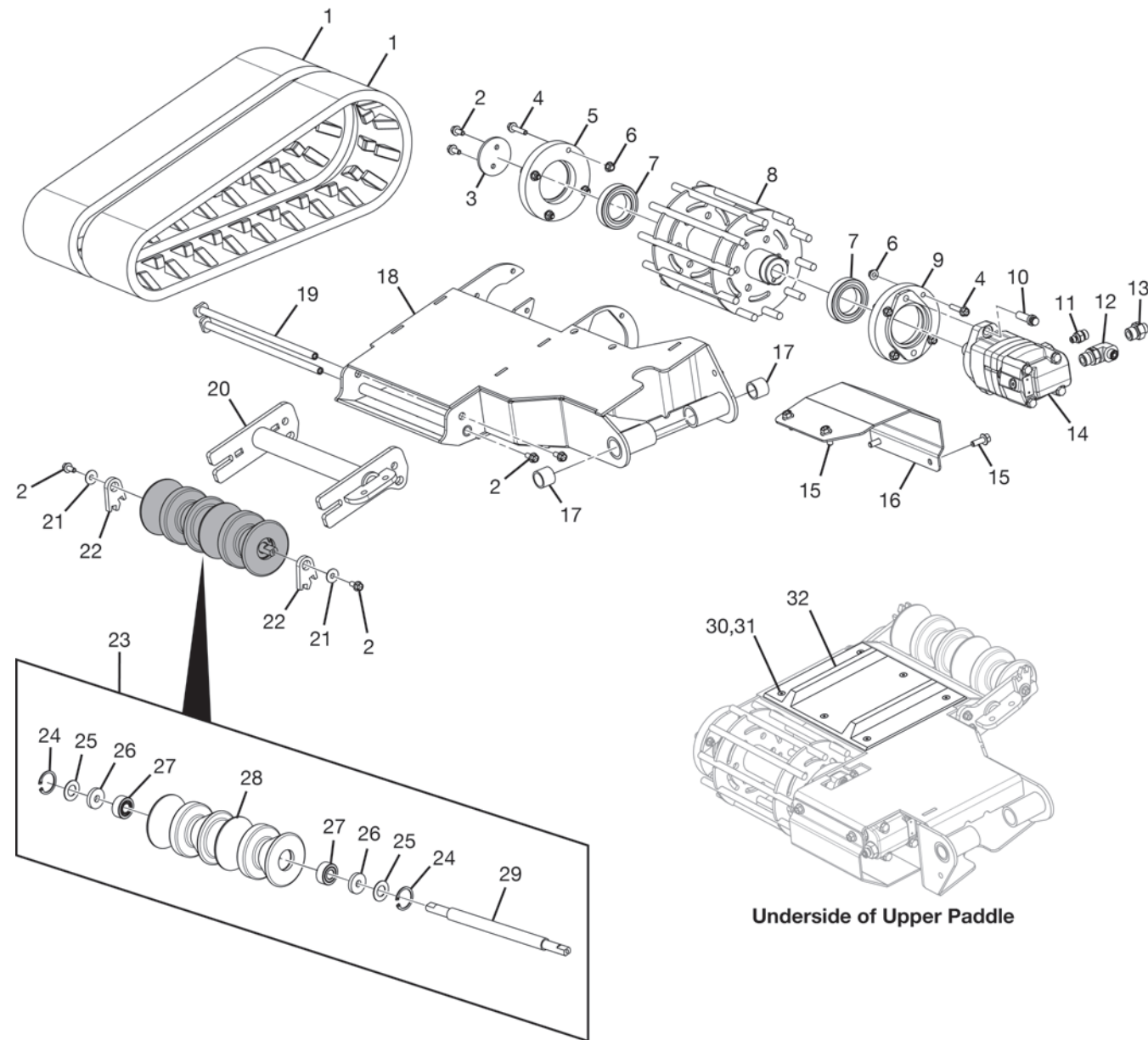

Underside of Upper Paddle

For hydraulic hoses, with part numbers, refer to the schematic on page 40.

Upper Paddle Assembly

#	QTY.	PART #	DESCRIPTION
1	2	00000574	TRACK, ARIENS
2	6	00002180	BOLT, 5/16-18 X .75 FLANGE GR5
3	1	00001946	PLATE, BEARING HOLDER ENDCAP
4	8	00002181	BOLT, 5/16-18 X 1-1/2 GR 5 FLANGE
5	1	00001949	HOLDER, SHAFT MOUNT BEARING
6	8	00002184	NUT, LOCK 5/16 FLANGE
7	2	00000142	BEARING, 50MM ID BALL
8	1	00001952	SPROCKET, ARIENS TRACK DRIVE
9	1	00001948	MOUNT, MOTOR BEARING HOLDER
10	2	00002469	BOLT, 1/2" X 1-1/2" 12PT GRD 8
11	1	00002468	ADAPTER, 6ORFS - 4MOR
12	1	00002133	ELBOW, 90 DEG - 6ORFS - 10MOR
13	1	00002261	ADAPTER, -6MORFS -10MOR
14	1	00000071	MOTOR
15	4	00002123	BOLT, 3/8 X 1 FLANGE
16	1	00002262	PLATE, UPPER PADDLE MOTOR
17	2	00002124	BEARING, 1IN SLEEVE 863 HIGH LOAD
18	1	00002362	WELDMENT, P17 UPPER FRAME
19	2	00002387	PIN, YOKE
20	1	00002336	WELDMENT, IDLER PRONG
21	2	00002132	WASHER, FLAT 5/16 OVERSIZED YC
22	2	00002170	PLATE, IDLER TENSIONER TAB
23	1	00001666	ASM, FLAT TRACK IDLER
24	2	00000588	RING, RETAINING 40MM
25	2	00000586	WASHER, FLAT 3/4 SST
26	2	00000587	WASHER, .5 X 1.5 WOOL FELT
27	2	00000174	BEARING, 17MM DOUBLE ROW THRUST
28	1	00001667	WHEEL, IDLER
29	1	00001668	SHAFT, P17 IDLER
30	6	00002534	NUT, LOCK 1/4 NYLOCK LOW PROF
31	6	00002182	SCREW, FHCS 1/4-20 X 3/4 PLATED
32	1	00001947	GUIDE, TRACK

## Parts Identification

### Lower Paddle

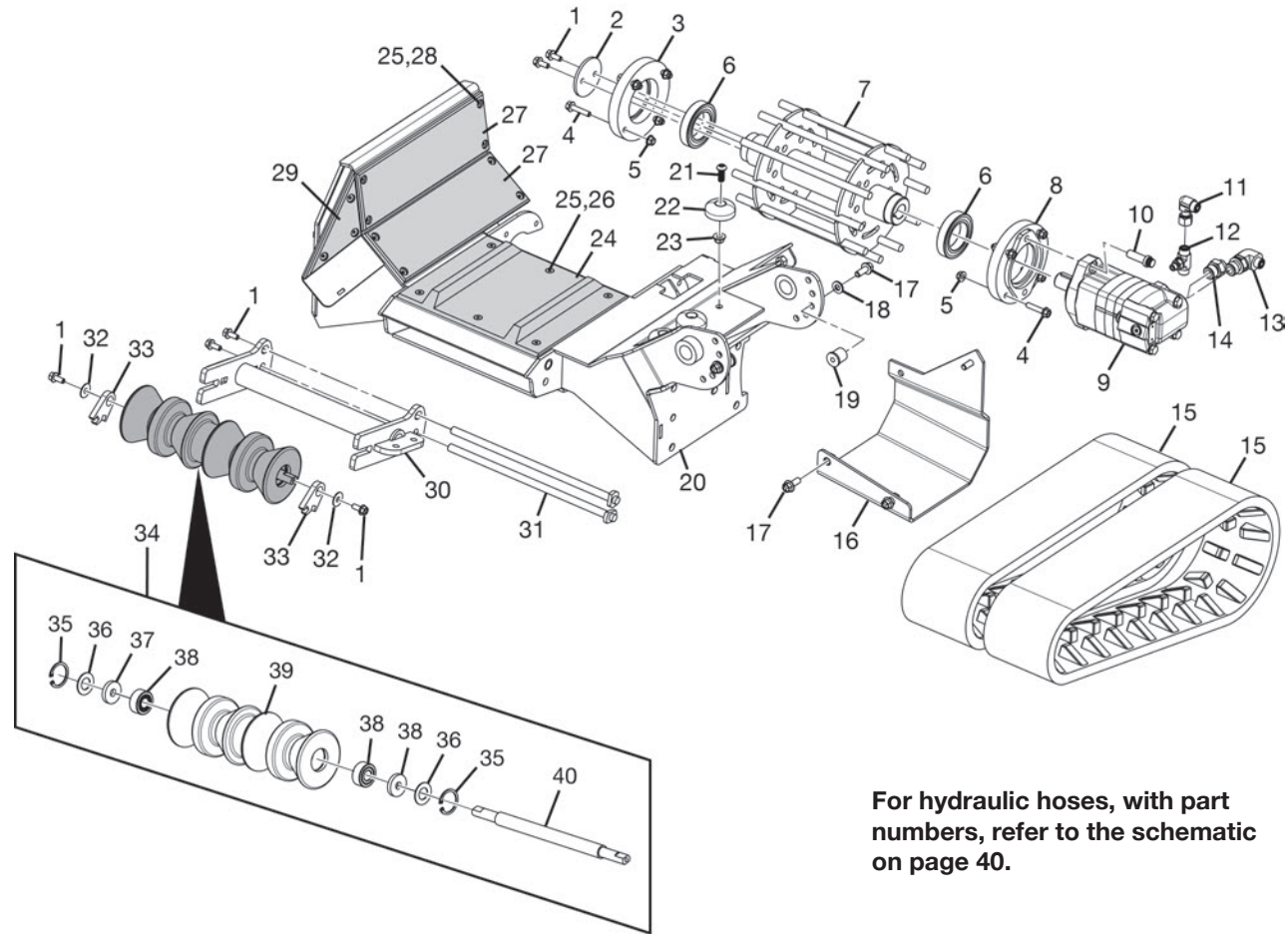

For hydraulic hoses, with part numbers, refer to the schematic on page 40.

#	QTY.	PART #	DESCRIPTION
1	6	00002180	BOLT, 5/16-18 X .75 FLANGE GR5
2	1	00001946	PLATE, BEARING HOLDER ENDCAP
3	1	00001949	HOLDER, SHAFT MOUNT BEARING
4	8	00002181	BOLT, 5/16-18 X 1-1/2 GR 5 FLANGE
5	8	00002184	NUT, LOCK 5/16 FLANGE
6	2	00000142	BEARING, 50MM ID BALL
7	1	00001952	SPROCKET, ARIENS TRACK DRIVE
8	1	00001948	MOUNT, MOTOR BEARING HOLDER
9	1	00000071	MOTOR
10	2	00002469	BOLT, 1/2" X 1-1/2" 12PT GRD 8
11	1	00002471	ELBOW, 90DEG -6MORFS -6FORFS
12	1	00002330	TEE, 06MORFS -06MORFS -04MOR

## Parts Identification

### Lower Paddle

#	QTY.	PART #	DESCRIPTION
13	1	00002133	ELBOW, 90 DEG - 6ORFS - 10MOR
14	1	00002261	ADAPTER, -6MORFS -10MOR
15	2	00000574	TRACK, ARIENS
16	1	00002310	COVER, LOWER MOTOR
17	6	00002123	BOLT, 3/8 X 1 FLANGE
18	2	00002532	WASHER, NORD-LOCK 3/8" SP
19	2	00002470	SHAFT, 3/8-16 THREADED
20	1	00002363	WELDMENT, P17 LOWER FRAME
21	3	00002189	BOLT, BHCS 3/8 X 1-16
22	3	00002135	BUMPER, HEAVY-DUTY UNTHREADED
23	3	00002187	NUT, LOCK 3/8 FLANGE
24	1	00001947	GUIDE, TRACK
25	17	00002182	SCREW, FHCS 1/4-20 X 3/4 PLATED
26	6	00002534	NUT, LOCK 1/4 NYLOCK LOW PROF
27	2	00001995	PAD, P17 EE UHMW
28	11	00002183	NUT, LOCK 1/4-20 NYLOCK
29	1	00001996	PAD, TRIANGLE SLIDE
30	1	00002336	WELDMENT, IDLER PRONG
31	2	00002387	PIN, YOKE
32	2	00002132	WASHER, FLAT 5/16 OVERSIZED YC
33	2	00002170	PLATE, IDLER TENSIONER TAB
34	1	00001666	ASM, FLAT TRACK IDLER
35	2	00000588	RING, RETAINING 40MM
36	2	00000586	WASHER, FLAT 3/4 SST
37	2	00000587	WASHER, .5 X 1.5 WOOL FELT
38	2	00000174	BEARING, 17MM DOUBLE ROW THRUST
39	1	00001667	WHEEL, IDLER
40	1	00001668	SHAFT, P17 IDLER

Carriage Assembly

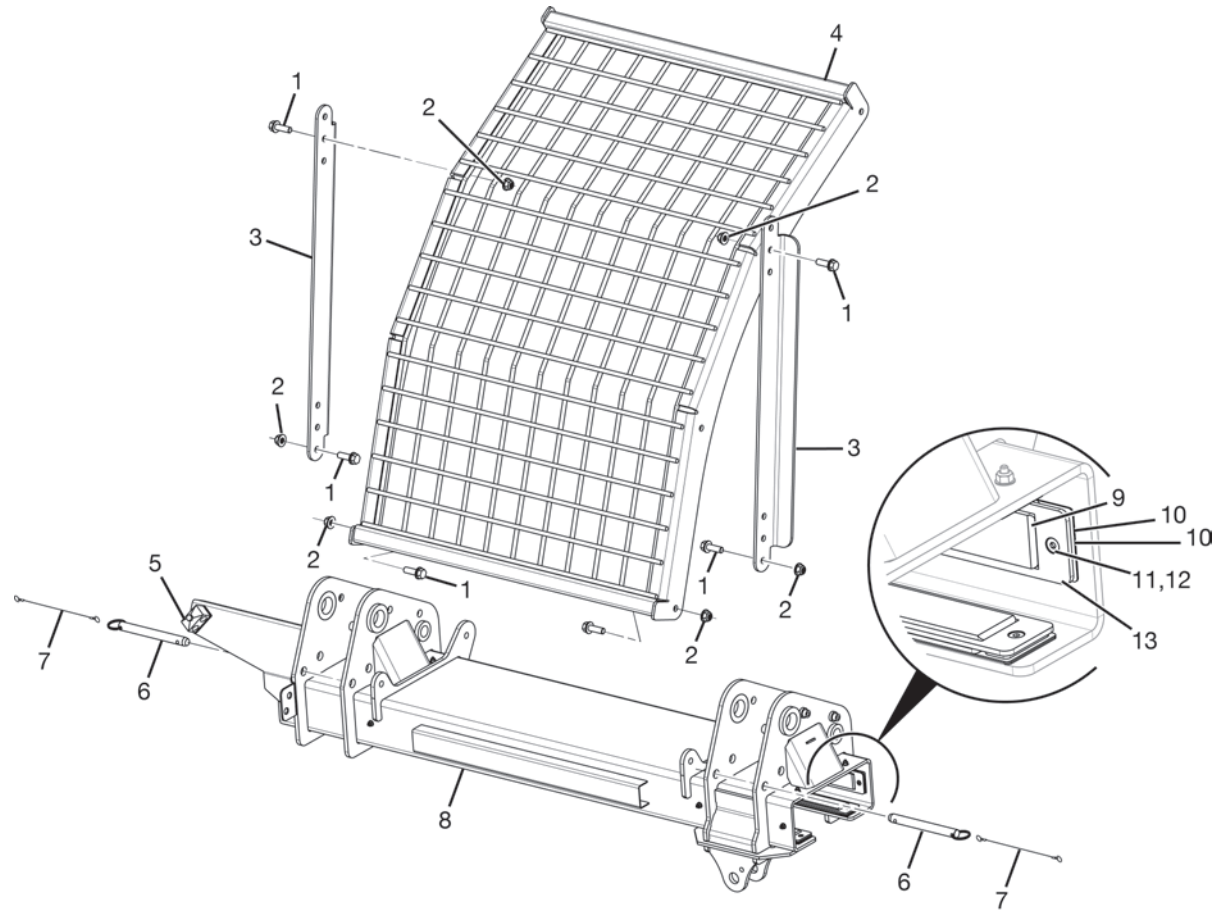

#	QTY.	PART #	DESCRIPTION
1	6	00000062	BOLT, 1/2-13 X 1-1/2 FLG
2	6	00000061	NUT, LOCK 1/2 NYLOCK FLANGE
3	2	00002393	PLATE, ROCK GUARD STRUT ADJ LG
4	1	00002410	WELDMENT, ROCK GUARD LONG
5	1	00000126	CLAMP, 3/8" DOUBLE HOSE
6	2	00002148	PIN, 3/4 X 6" USEABLE QUICK REL
7	2	00002507	LANYARD, 12 SS W/QUICK RELEASE
8	1	00002364	WELDMENT, CARRIAGE
9	12	00001989	PAD, CARRIAGE BEARING
10	24	00002246	PLATE, CARRIAGE PAD SHIM
11	24	00002298	SCREW, FHCS 10-24 X 1
12	24	00002151	NUT, LOCK 10-24 NYLOCK FLANGED
13	12	00001992	ASSY, PAD RETENTION FRAME

Hydraulic Valve

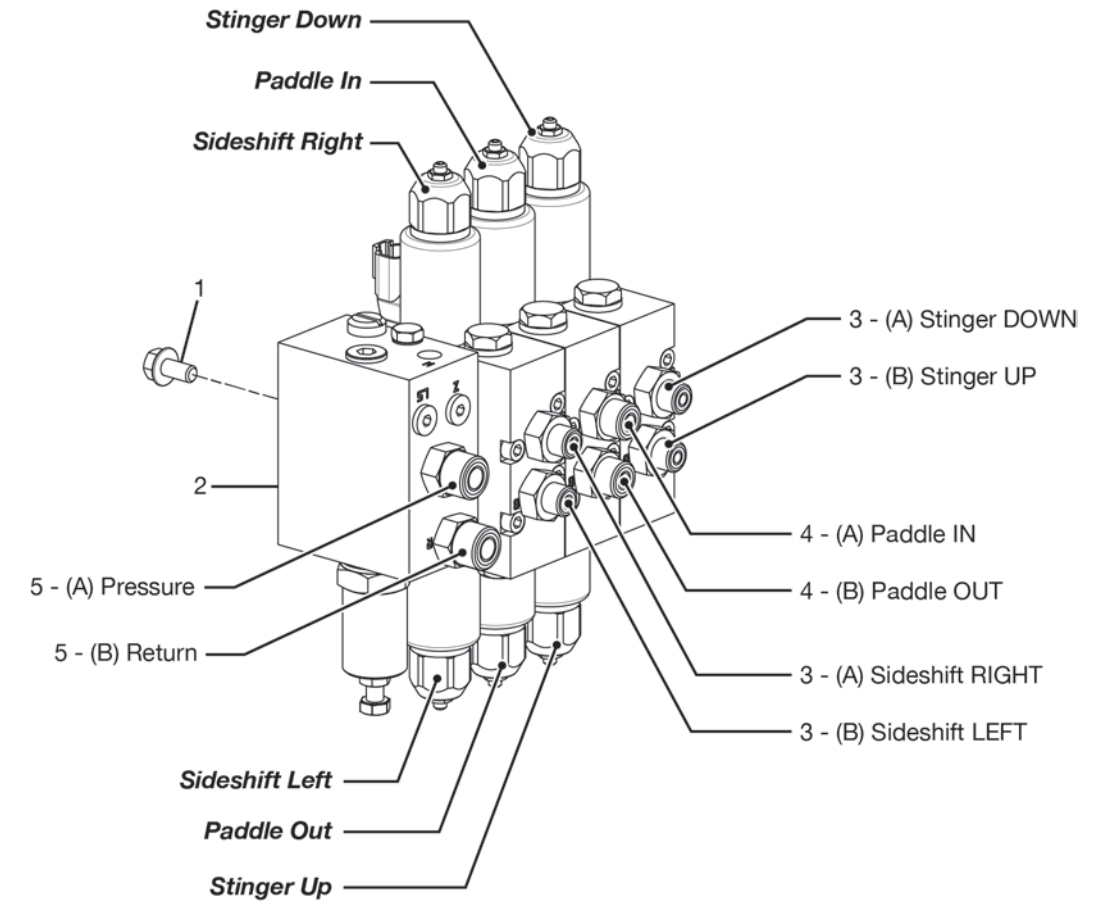

#	QTY.	PART #	DESCRIPTION
1	4	00000454	BOLT, M8 X 16 MM GR 8.8 FLANGE
2	1	00002061	VALVE, HAWE EDL 3 SECTION FLAT
3	4	00002049	ADAPTER, -4MORFS -8MOR
4	2	00002050	ADAPTER, -6MORFS -8MOR
5	2	00002036	ADAPTER, -8MORFS -8MOR

Hydraulic Hoses, with Schematic

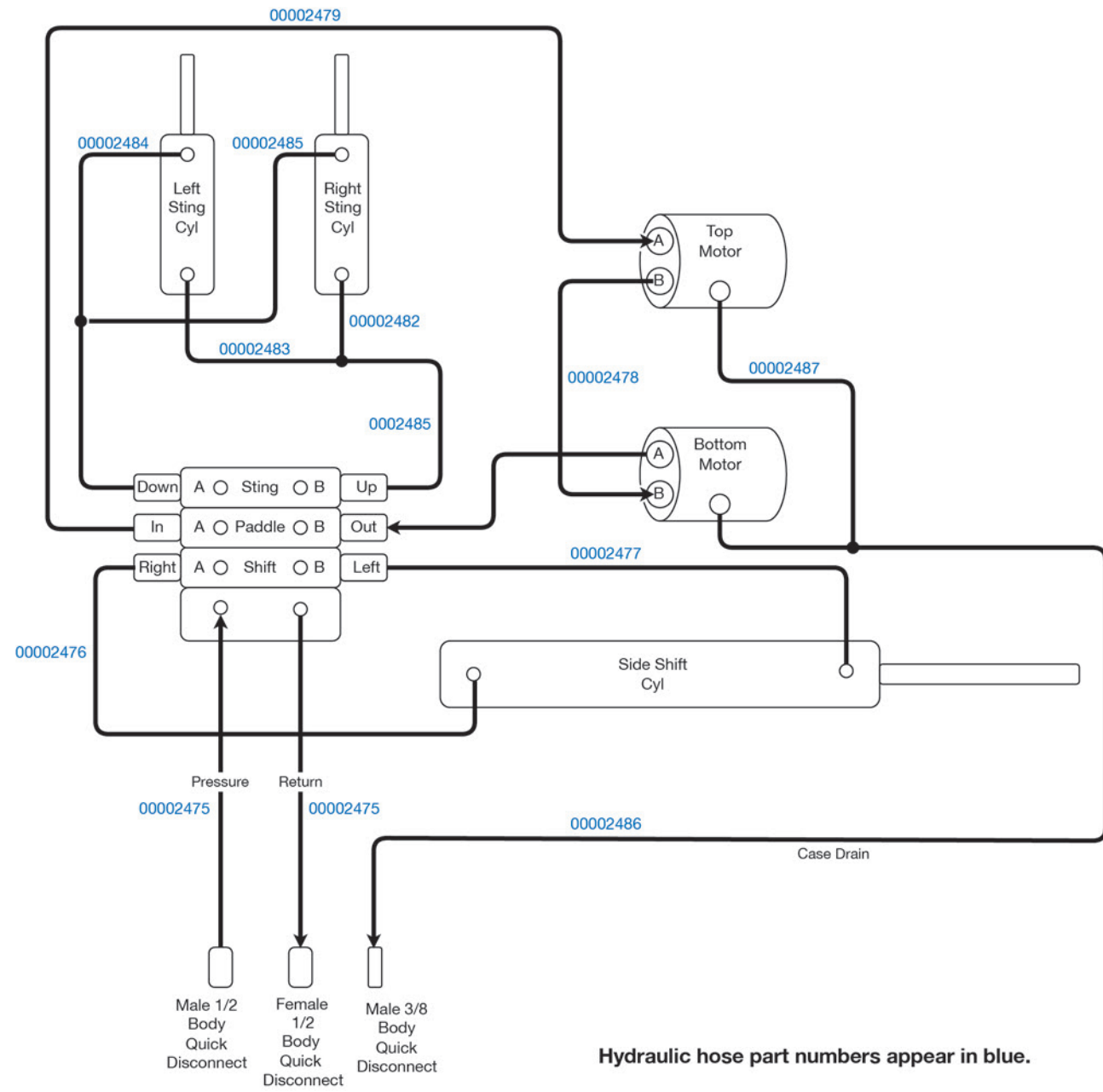

Electrical Schematic

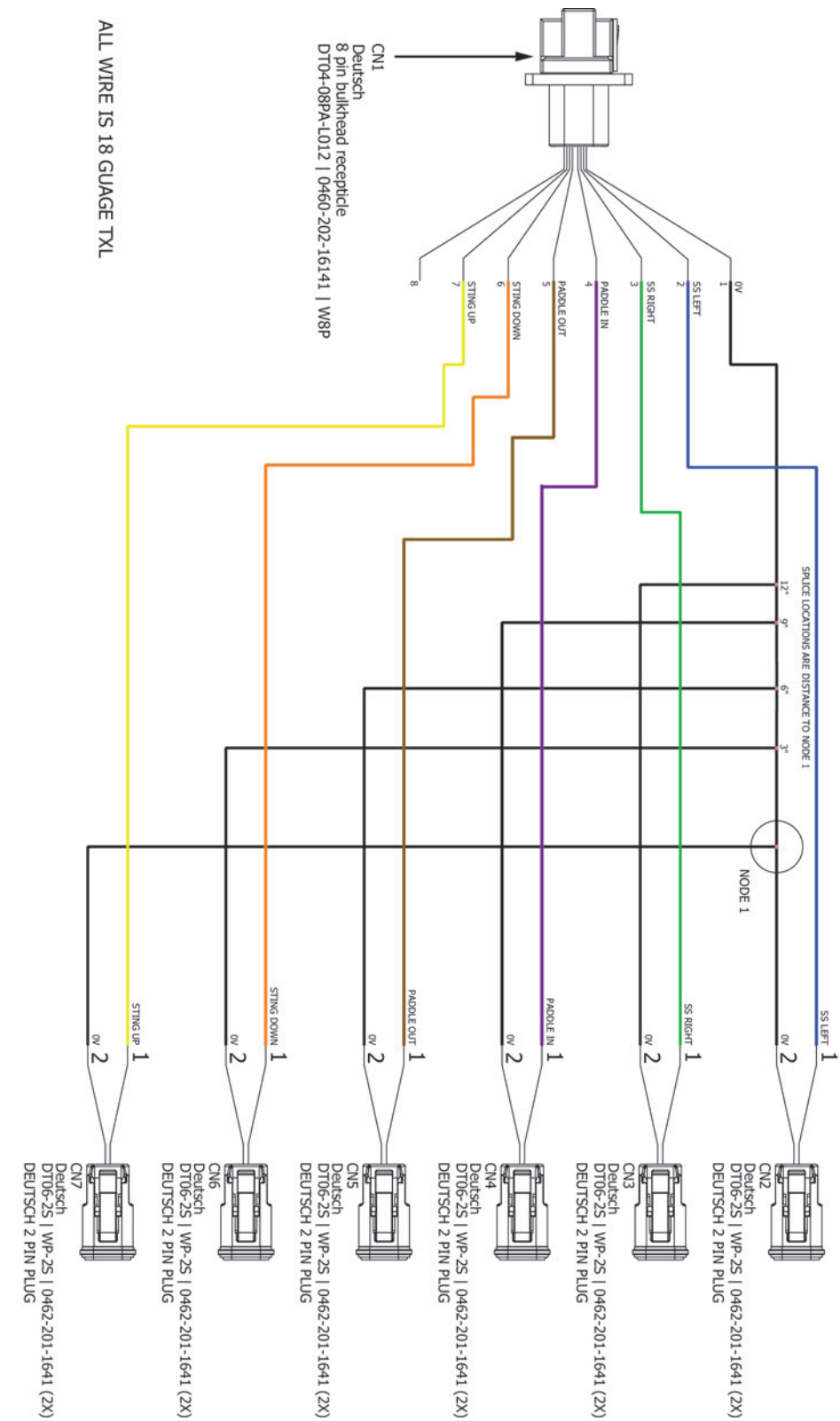

Specifications

DESCRIPTION	TC100 Rock Picker
Min. flow requirement	18 GPM
Pressure requirement	2,900 PSI
Case drain fitting	3/8" Flat face
Pressure fitting	1/2" Flat face
Return fitting	1/2" Flat face
Hitch plate	Standard
Tipping load	8,600 lbs. (3,900 kg) of 100% operating weight
Bucket volume	1 Cubic yard
Electrical	14-pin round Deutsch with 6 AUX pins and ground
Rock size capacity	6" - 26" (15 cm - 66 cm) diameter

Dimensions

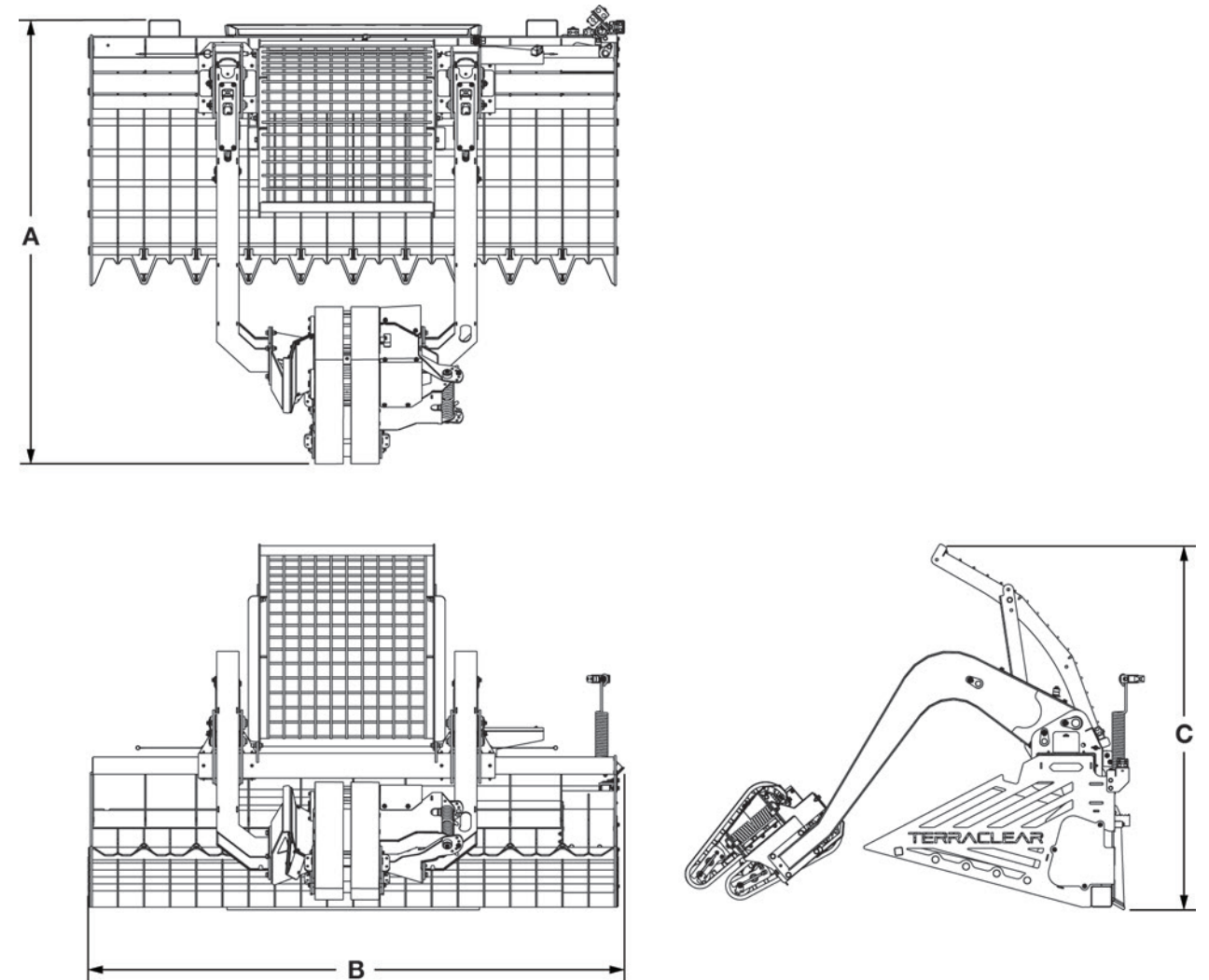

DESCRIPTION	TC100 Rock Picker
Rock Picker Depth (A)	85.0 in. (215.9 cm)
Rock Picker Width (B)	102.5 in. (260.4 cm)
Rock Picker Height (C) - <i>Not including Paddle location</i>	69.6 in. (176.8 cm)
Weight (Base Unit)	1,950 lbs. (884.5 kg)

Torque Specifications

Inches Hardware and Lock Nuts

**TORQUE CHARTS**  
Minimum Hardware Tightening Torques  
Normal Assembly Applications  
(Standard Hardware and Lock Nuts)

SAE Gr. 2 Nominal Size	SAE Grade 5		SAE Grade 8		LOCK NUTS			
	Unplated or Plated Silver	Plated W / ZnCr Gold	Unplated or Plated Silver	Plated W / ZnCr Gold	Unplated or Plated Silver	Plated W / ZnCr Gold	Grade W / Gr. 5 Bolt	Grade W / Gr. 8 Bolt
1/4	55 in.-lb. (6.2 N•m)	72 in.-lb. (8.1 N•m)	86 in.-lb. (9.7 N•m)	112 in.-lb. (12.6 N•m)	121 in.-lb. (13.6 N•m)	157 in.-lb. (17.7 N•m)	61 in.-lb. (6.9 N•m)	86 in.-lb. (9.8 N•m)
5/16	115 in.-lb. (13 N•m)	149 in.-lb. (17 N•m)	178 in.-lb. (20 N•m)	229 in.-lb. (26 N•m)	250 in.-lb. (28 N•m)	324 in.-lb. (37 N•m)	125 in.-lb. (14 N•m)	176 in.-lb. (20 N•m)
3/8	17 ft.-lb. (23 N•m)	22 ft.-lb. (30 N•m)	26 ft.-lb. (35 N•m)	34 ft.-lb. (46 N•m)	37 ft.-lb. (50 N•m)	48 ft.-lb. (65 N•m)	19 ft.-lb. (26 N•m)	26 ft.-lb. (35 N•m)
7/16	27 ft.-lb. (37 N•m)	35 ft.-lb. (47 N•m)	42 ft.-lb. (57 N•m)	54 ft.-lb. (73 N•m)	59 ft.-lb. (80 N•m)	77 ft.-lb. (104 N•m)	30 ft.-lb. (41 N•m)	42 ft.-lb. (57 N•m)
1/2	42 ft.-lb. (57 N•m)	54 ft.-lb. (73 N•m)	64 ft.-lb. (87 N•m)	83 ft.-lb. (113 N•m)	91 ft.-lb. (123 N•m)	117 ft.-lb. (159 N•m)	45 ft.-lb. (61 N•m)	64 ft.-lb. (88 N•m)
9/16	60 ft.-lb. (81 N•m)	77 ft.-lb. (104 N•m)	92 ft.-lb. (125 N•m)	120 ft.-lb. (163 N•m)	130 ft.-lb. (176 N•m)	169 ft.-lb. (229 N•m)	65 ft.-lb. (88 N•m)	92 ft.-lb. (125 N•m)
5/8	83 ft.-lb. (112 N•m)	107 ft.-lb. (145 N•m)	128 ft.-lb. (174 N•m)	165 ft.-lb. (224 N•m)	180 ft.-lb. (244 N•m)	233 ft.-lb. (316 N•m)	90 ft.-lb. (122 N•m)	127 ft.-lb. (172 N•m)
3/4	146 ft.-lb. (198 N•m)	189 ft.-lb. (256 N•m)	226 ft.-lb. (306 N•m)	293 ft.-lb. (397 N•m)	319 ft.-lb. (432 N•m)	413 ft.-lb. (560 N•m)	160 ft.-lb. (217 N•m)	226 ft.-lb. (306 N•m)
7/8	142 ft.-lb. (193 N•m)	183 ft.-lb. (248 N•m)	365 ft.-lb. (495 N•m)	473 ft.-lb. (641 N•m)	515 ft.-lb. (698 N•m)	667 ft.-lb. (904 N•m)	258 ft.-lb. (350 N•m)	364 ft.-lb. (494 N•m)
1	213 ft.-lb. (289 N•m)	275 ft.-lb. (373 N•m)	547 ft.-lb. (742 N•m)	708 ft.-lb. (960 N•m)	773 ft.-lb. (1048 N•m)	1000 ft.-lb. (1356 N•m)	386 ft.-lb. (523 N•m)	545 ft.-lb. (739 N•m)

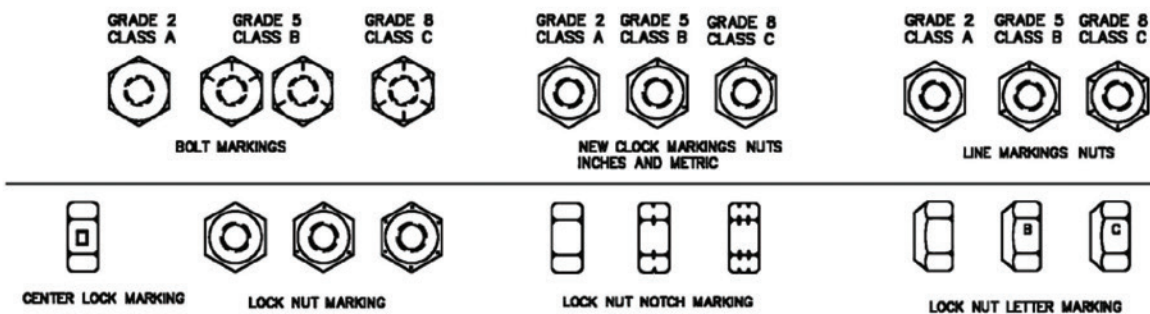

Torque Specifications (Cont'd)

Metric Hardware and Lock Nuts

**TORQUE CHARTS**  
Minimum Hardware Tightening Torques  
Normal Assembly Applications  
(Metric Hardware and Lock Nuts)

Nominal Size	Class 5,8		Class 8,8		Class 10,9		Lock nuts
	Unplated or Plated Silver	Plated W / ZnCr Gold	Unplated or Plated Silver	Plated W / ZnCr Gold	Unplated or Plated Silver	Plated W / ZnCr Gold	Class 8 W / CL. 8,8 Bolt
M4	1.7 N•m (15 in.-lb.)	2.2 N•m (19 in.-lb.)	2.6 N•m (23 in.-lb.)	3.4 N•m (30 in.-lb.)	3.7 N•m (33 in.-lb.)	4.8 N•m (42 in.-lb.)	1.8 N•m (16 in.-lb.)
M6	5.8 N•m (51 in.-lb.)	7.6 N•m (67 in.-lb.)	8.9 N•m (79 in.-lb.)	12 N•m (102 in.-lb.)	13 N•m (115 in.-lb.)	17 N•m (150 in.-lb.)	6.3 N•m (56 in.-lb.)
M8	14 N•m (124 in.-lb.)	18 N•m (159 in.-lb.)	22 N•m (195 in.-lb.)	28 N•m (248 in.-lb.)	31 N•m (274 in.-lb.)	40 N•m (354 in.-lb.)	15 N•m (133 in.-lb.)
M10	28 N•m (21 ft.-lb.)	36 N•m (27 ft.-lb.)	43 N•m (32 ft.-lb.)	56 N•m (41 ft.-lb.)	61 N•m (45 ft.-lb.)	79 N•m (58 ft.-lb.)	30 N•m (22 ft.-lb.)
M12	49 N•m (36 ft.-lb.)	63 N•m (46 ft.-lb.)	75 N•m (55 ft.-lb.)	97 N•m (72 ft.-lb.)	107 N•m (79 ft.-lb.)	138 N•m (102 ft.-lb.)	53 N•m (39 ft.-lb.)
M16	121 N•m (89 ft.-lb.)	158 N•m (117 ft.-lb.)	186 N•m (137 ft.-lb.)	240 N•m (177 ft.-lb.)	266 N•m (196 ft.-lb.)	344 N•m (254 ft.-lb.)	131 N•m (97 ft.-lb.)
M20	237 N•m (175 ft.-lb.)	307 N•m (226 ft.-lb.)	375 N•m (277 ft.-lb.)	485 N•m (358 ft.-lb.)	519 N•m (383 ft.-lb.)	671 N•m (495 ft.-lb.)	265 N•m (195 ft.-lb.)
M24	411 N•m (303 ft.-lb.)	531 N•m (392 ft.-lb.)	648 N•m (478 ft.-lb.)	839 N•m (619 ft.-lb.)	897 N•m (662 ft.-lb.)	1160 N•m (855 ft.-lb.)	458 N•m (338 ft.-lb.)

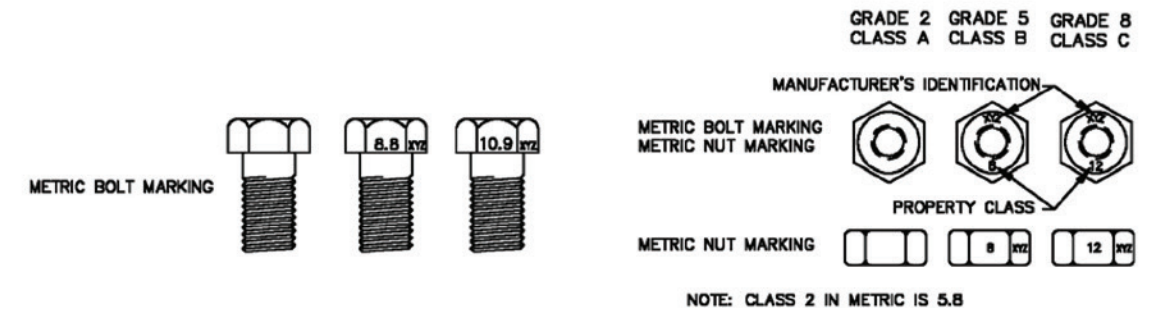

# TERRACLEAR

TerraClear Inc.

1770 NW Maple St.  
Issaquah, WA 98027

1101 Hill Street  
Grangeville, ID 83530

[info@terraclear.com](mailto:info@terraclear.com)

(425) 274-2905

Printed in USA

© TerraClear Inc. 2025